



QUADRANT 5300

Quick Start Guide 2020

Refer to Operator's Manual for proper operation and safety instructions!

CLAAS



Important Information

- This operator training document does **not** replace the Operator's Manual
- Information about **accident hazards must be taken from the Operator's Manual before putting the machine into operation**
- At the beginning of the operator training, participants will be informed about the position and significance of the warning signs as well as the associated hazard points
- The operator training, as well as this document, is **unrelated** to the delivery of the product. The delivery advice must be filled in correctly by the sales partner (see Delivery process in accordance with the Customer Service guideline) and signed by the customer at the time of acceptance of the product.
- The training material serves the sole purpose of correct application and economic use of the machine
- For detailed information about the machine, please see the **Operator's Manual**, which is enclosed with the machine
- Optimal use of this documentation is only possible in conjunction with attendance of the CLAAS operator training course

Subject to changes.

Contents

- | | | | |
|-----------------------------------|---------|-------------------------------------|---------|
| ▪ <u>Warning information</u> | Page 5 | ▪ <u>Bale chamber</u> | Page 42 |
| ▪ <u>Performance requirement</u> | Page 7 | ▪ <u>Bale discharge</u> | Page 46 |
| ▪ <u>Component overview</u> | Page 8 | ▪ <u>Tying</u> | Page 47 |
| ▪ <u>ISOBUS control terminals</u> | Page 9 | ▪ <u>Knotter</u> | Page 49 |
| ▪ <u>Hitching</u> | Page 25 | ▪ <u>Twine guide</u> | Page 52 |
| ▪ <u>Drive</u> | Page 28 | ▪ <u>Central lubrication system</u> | Page 59 |
| ▪ <u>Flywheel</u> | Page 29 | ▪ <u>TURBOFAN</u> | Page 60 |
| ▪ <u>Pick-up</u> | Page 30 | ▪ <u>Steering axle</u> | Page 61 |
| ▪ <u>Feed systems</u> | Page 33 | ▪ <u>Moisture sensor</u> | Page 62 |
| ▪ <u>Cutting unit</u> | Page 34 | ▪ <u>Telematics</u> | Page 63 |
| ▪ <u>Pre-chamber</u> | Page 39 | ▪ <u>SPECIAL CUT front shredder</u> | Page 64 |



Tractor Requirements

- Required drive power → 1000 rpm (1-3/8" 21 spline or 1-3/4" 20 spline)
 - RF → 150 hp
 - RC → 180 hp
 - FC → 200 hp
- Required hydraulic output → 9.25-21 gal/min
- **Caution: Faults are often caused by problems with the power supply (direct power supply to the battery is the safest)**
- Electrical connections → 2-pin socket, 12 V, min. 25 A, min. 4 mm²
-  Power supply of the baler and control terminal

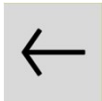

Component Overview

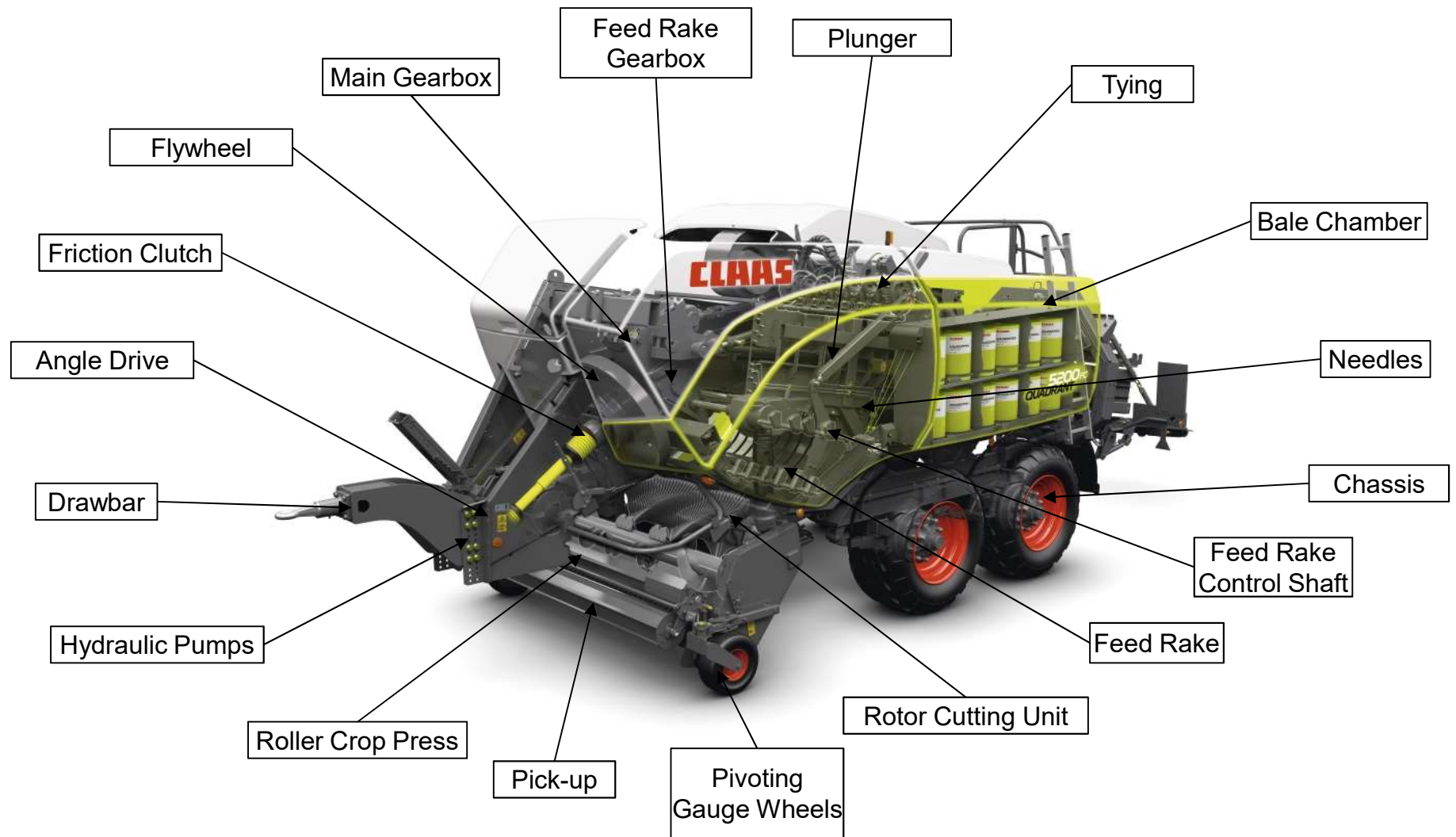



COMMUNICATOR II Operation

- 1. Play (programmable)
- 2. Stop (programmable)
- 3. Master switch
- 4. COMMUNICATOR menu
- 5. ESC = Return, cancel
- 6. Function keys
- 7. Assignment of tractor function keys and + keys (1) and (2)
- 8. Help key
- 9. Incremental encoder (rotary knob)

- 10. Buzzer
- 11. USB port

- A. ISOBUS connector
- B. Not used
- C. Not used

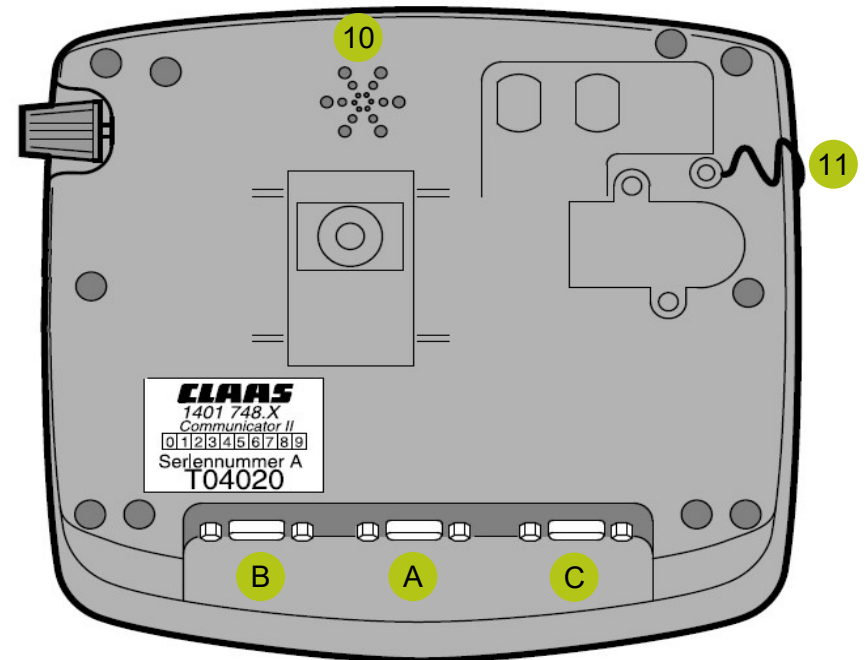

COMMUNICATOR II Service Menu Operation

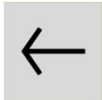

Information

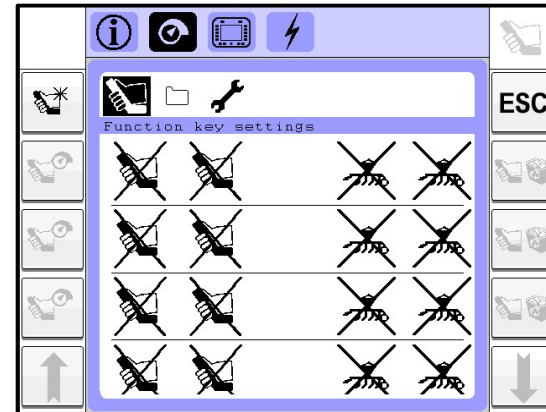

Settings

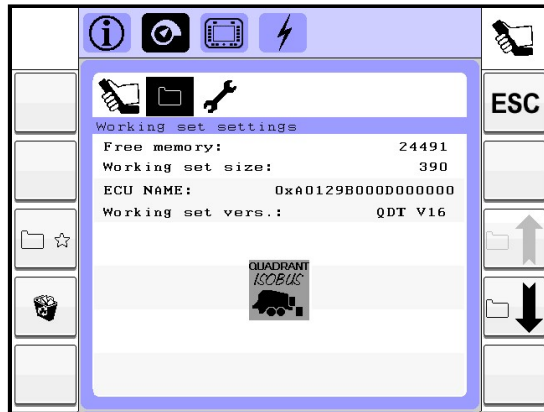

Data storage management

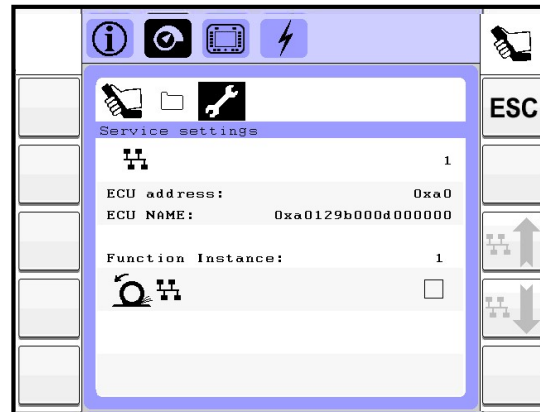

COMMUNICATOR diagnosis



Settings menu

iPad – CWI operation



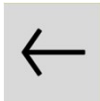

Operation – Menu Overview

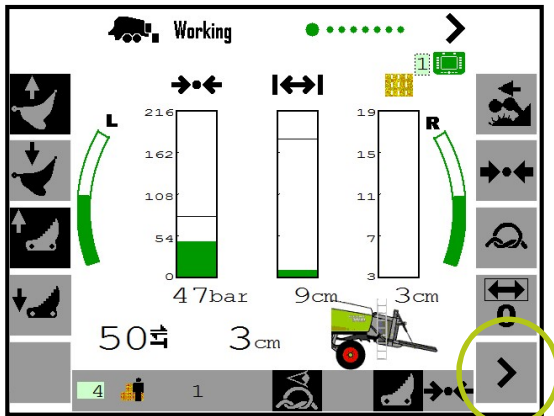

Working Menu

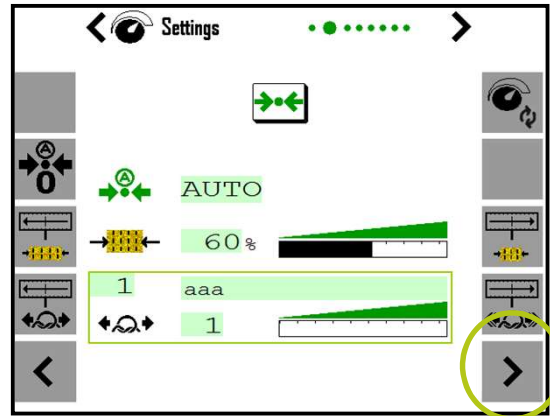

Settings Menu

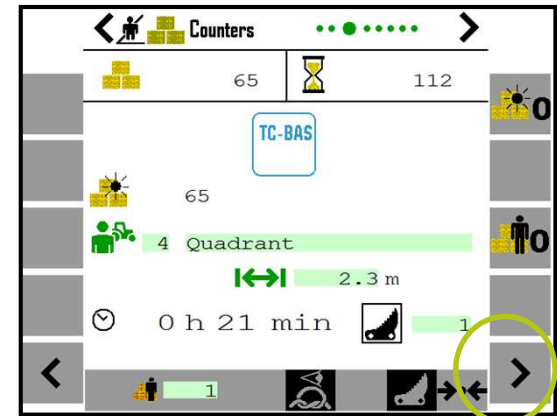

Counters Menu

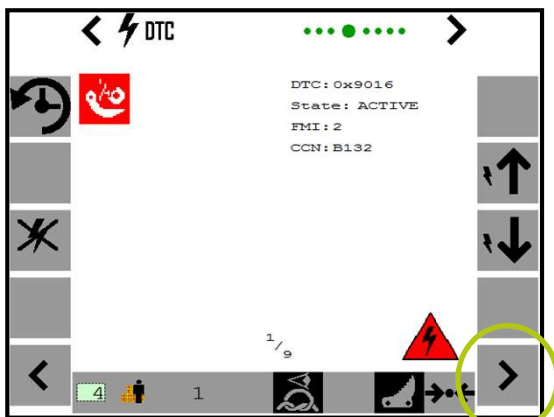

Error Menu

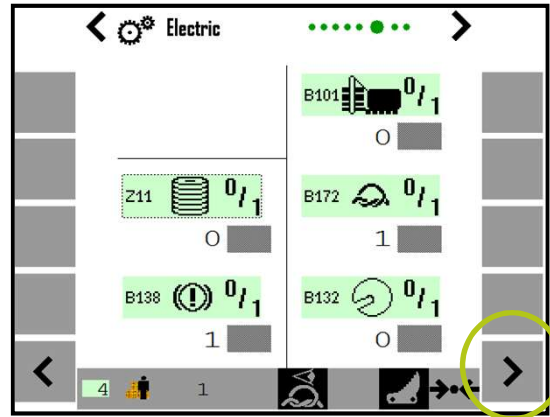

Diagnosis Menu

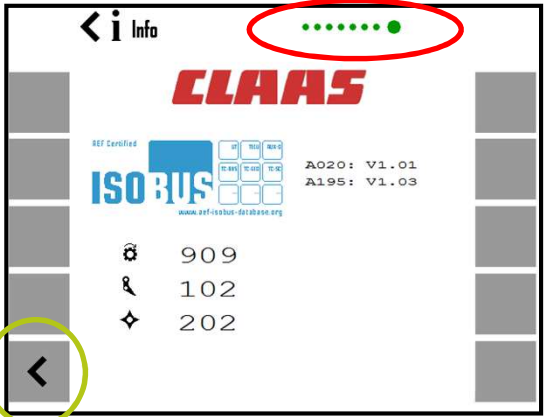

Information Menu



Operation – Start Screen

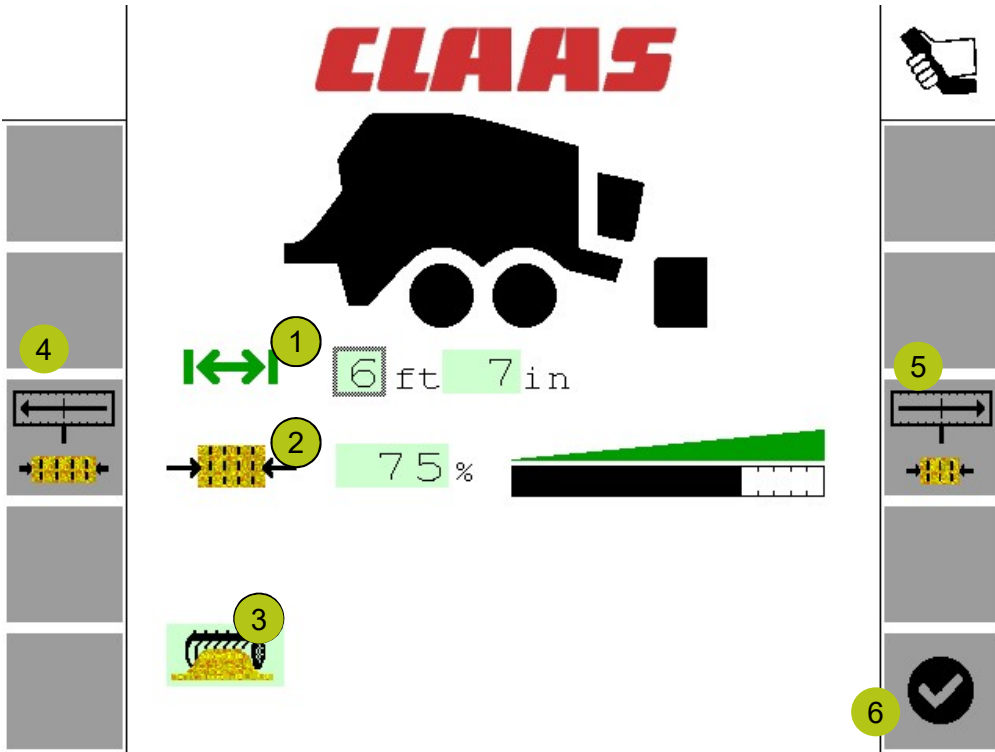

1. Set bale length
2. Max. bale density setting
3. Pre-chamber setting
4. Reduce bale density
5. Increase bale density
6. Exit start screen

For balers with hydraulic pickup, adjustments for setting pick-up speed would be available



Operation – Working Menu

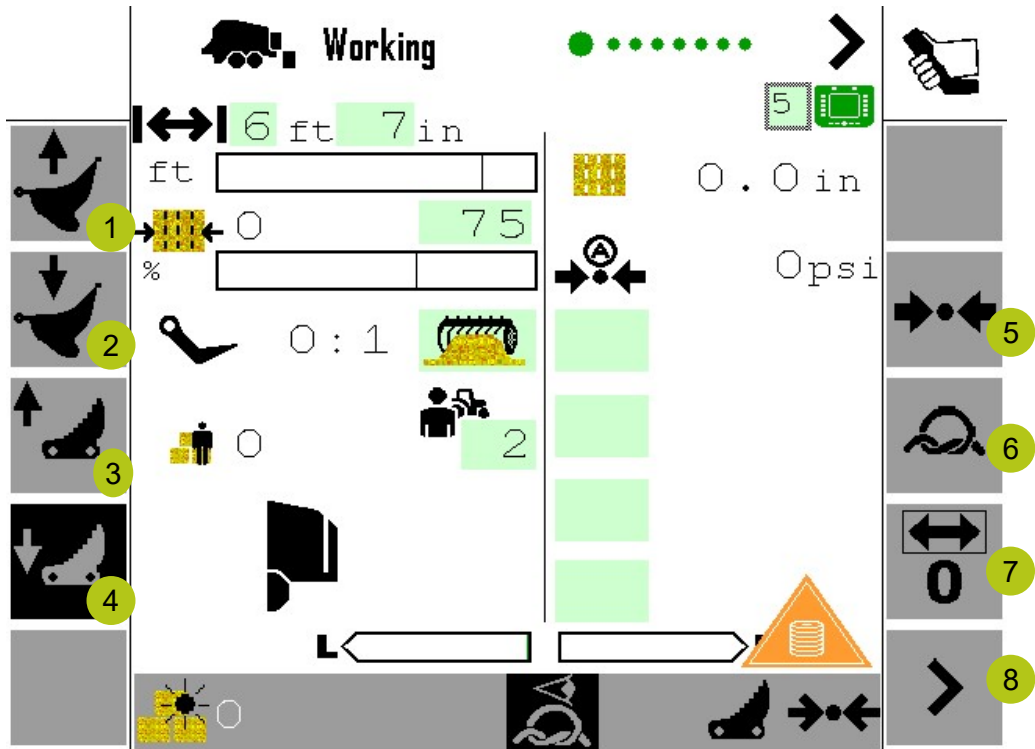

1. Raise drop floor
2. Lower drop floor
3. Engage knives
4. Disengage knives
5. Build up, reduce baling pressure
6. Manual tying (min 50 cm bale length)
7. Set bale length to 0
8. Switch working view (individual display options possible, see page 22)

Option: Pick-up reversing function (only possible with hydraulic pick-up drive)

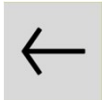

Operation – Working Menus

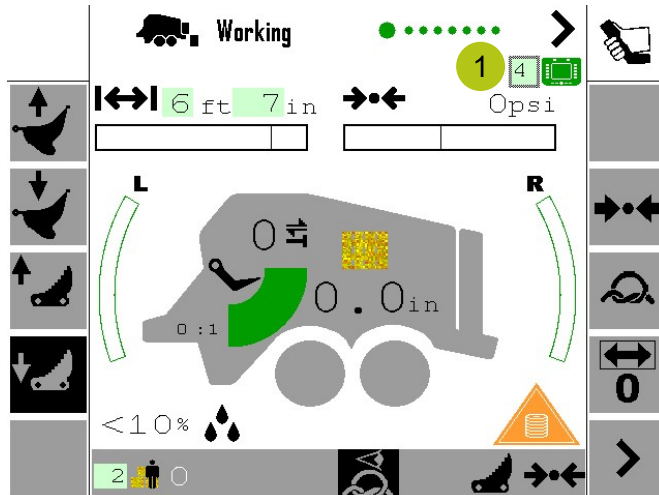
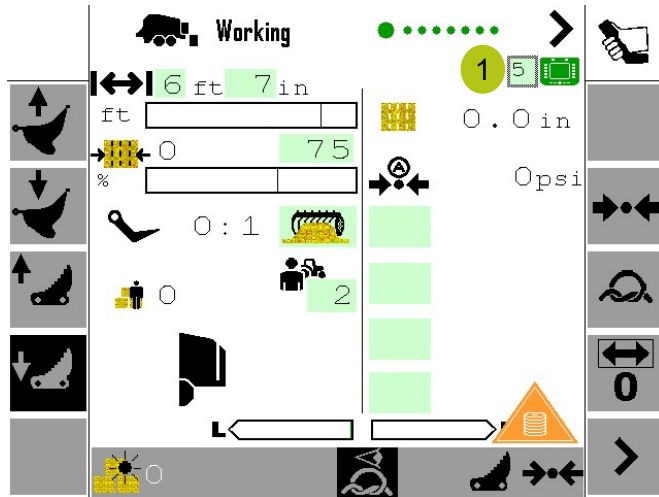

- Five individual display menus (1) available to choose from for the Working Menu display (several users)
- The key settings on the right and left sides always remain the same and are not freely assignable

	Number of bales
	Bale length
	Baling pressure
	Feed rake load
	Feed rake filling strokes
	Bale moisture
	APC density
	APC capacity utilisation
	Utilisation of the hydraulic pick-up
	Bale weight
	No display (hidden).

Operation – Settings

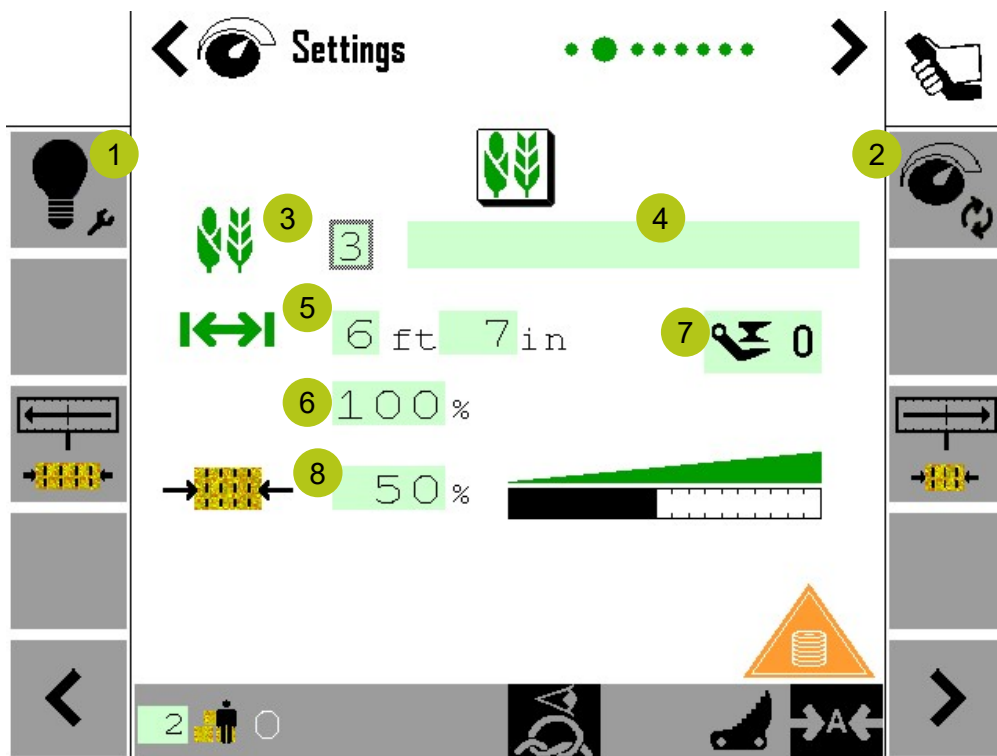

1. Switch on maintenance lights OPTIONAL
2. Switch between pages 1 to 4 of the Settings menu
3. Number of crop settings memory
4. Designation of crop
5. Set bale length
6. Bale length correction factor
7. Pre-chamber setting (Off – small swath – large swath)
8. Max. bale density setting

Operation – Settings

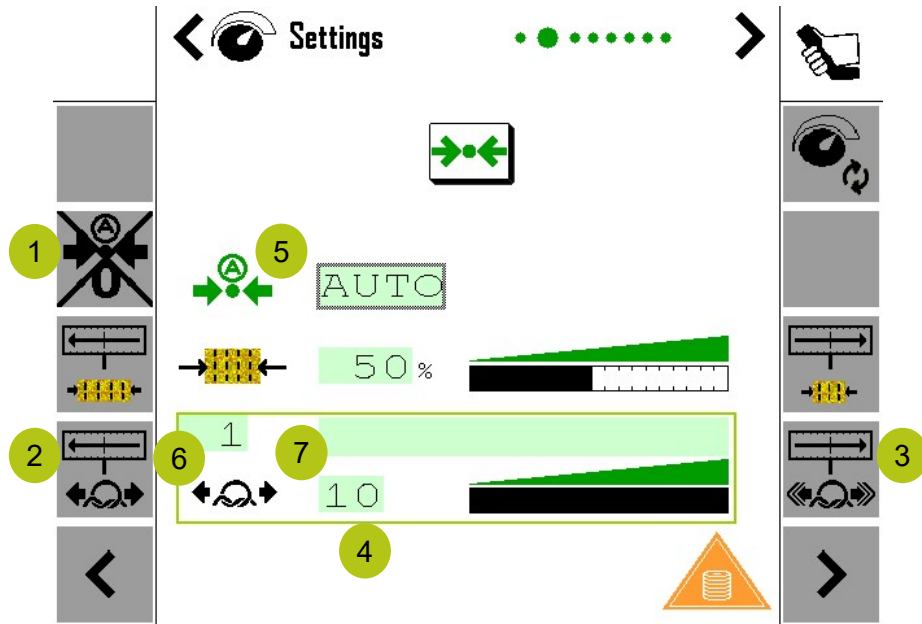
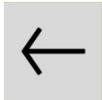

1. Teach in sensors for baling pressure control
2. Reduce permissible twine load
3. Increase permissible twine load
4. Permissible twine load indicator
5. Automatic baling pressure control on/off
6. Number of twine settings memory
7. Designation of twine

1. Switch between pages 1 to 4 of the Settings menu
2. Automatic baling pressure control on/off
3. Required baling pressure 5-200 bar (if the pressure is exceeded, the bale pressure is reduced by 50 bar)

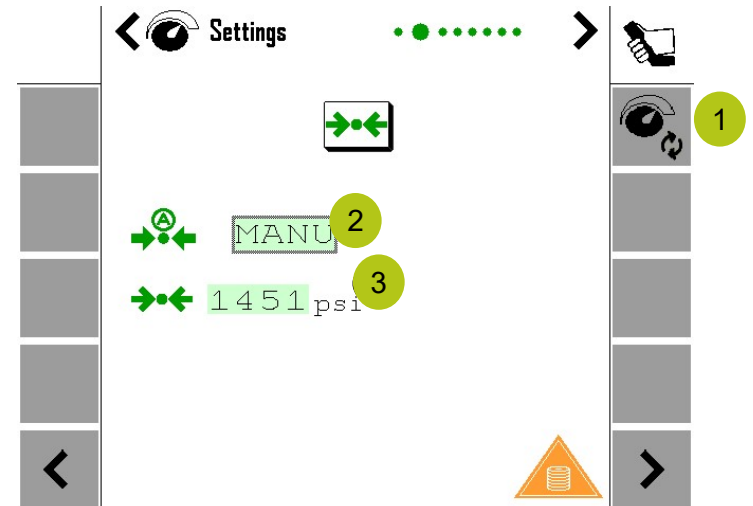

Operation – Settings

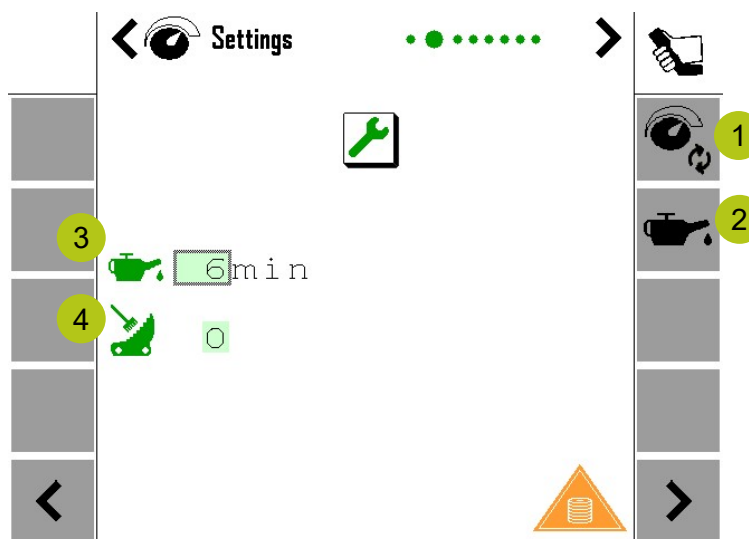

1. Switch between pages 1 to 4 of the Settings menu
2. Manual greasing cycle
3. Lubrication pause time 2–10 minutes
4. Switch knife cleaning on/off
IMPORTANT: With knife cleaning "on" → Select all knives
5. Current weight on the bale chute. Must be "0" with empty and bale chute lowered.

No calibration possible without workshop

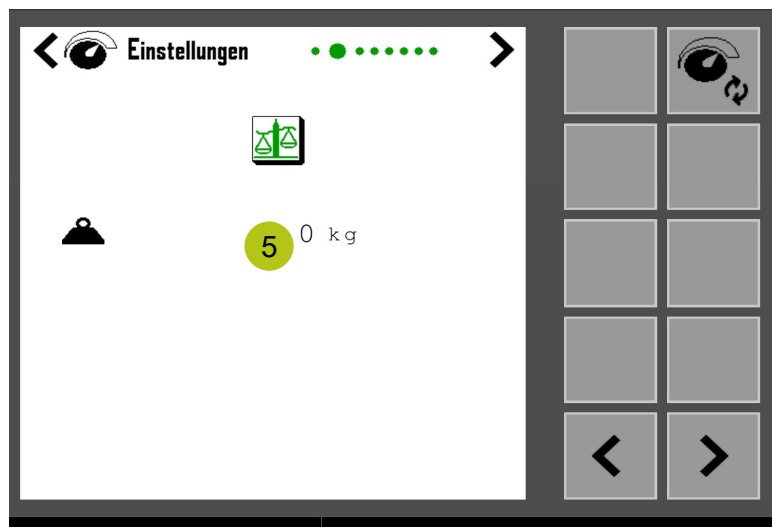

Operation – Settings

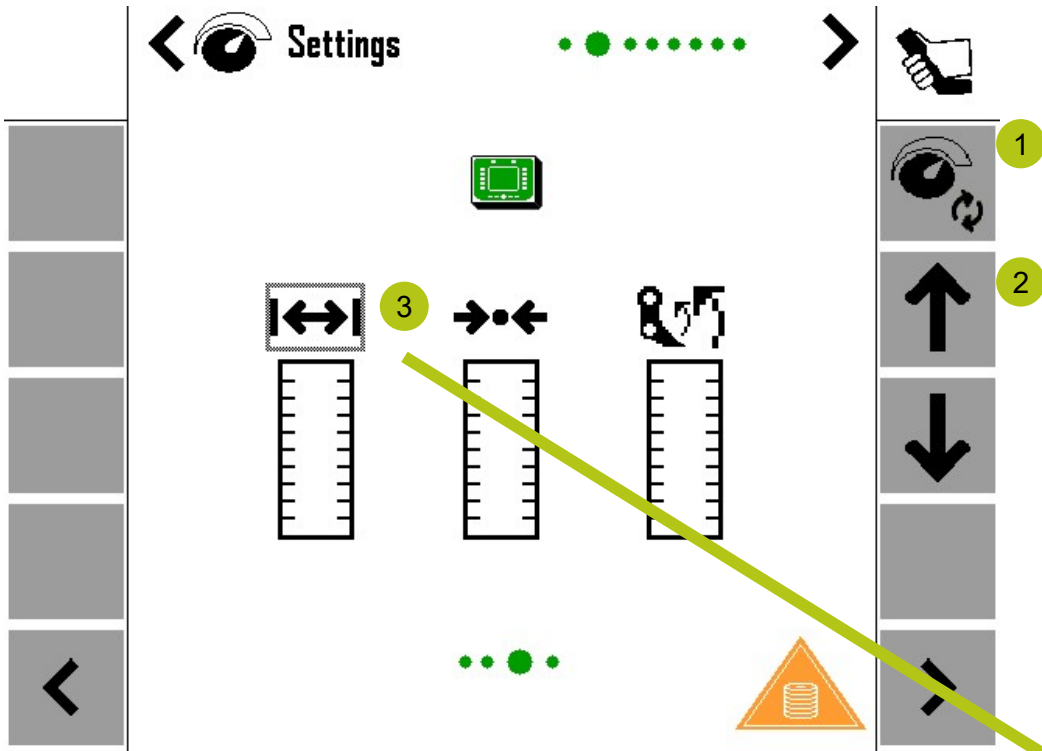
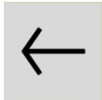

1. Switch between pages 1 to 4 of the Settings menu
2. Selection of pages 1 to 4 of the Working menu
3. Adapting the displays in the Working menu
4. Current selection
5. Actual bale length
6. Actual bale pressure
7. Number of feed rake strokes
8. Straw moisture OPTIONAL
9. Machine utilisation with active baling pressure control in %
10. Twine load indicator
11. Not assigned

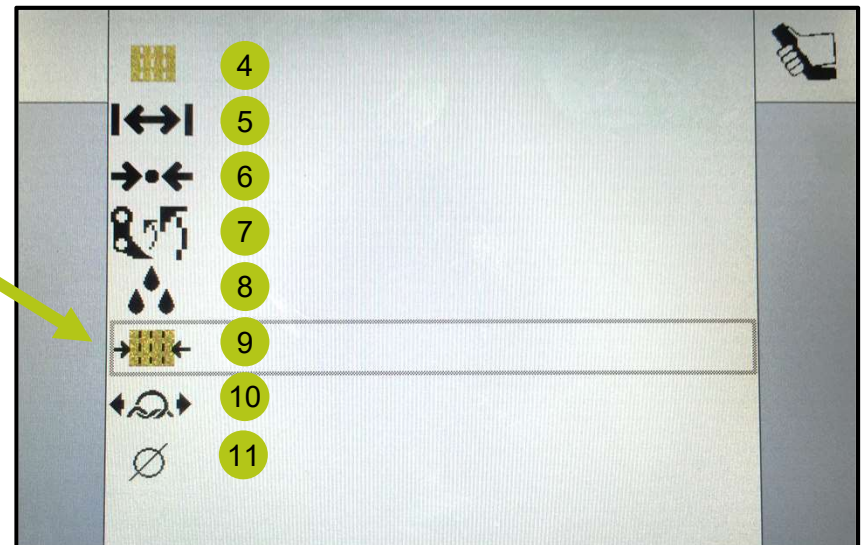

Operation – Counter

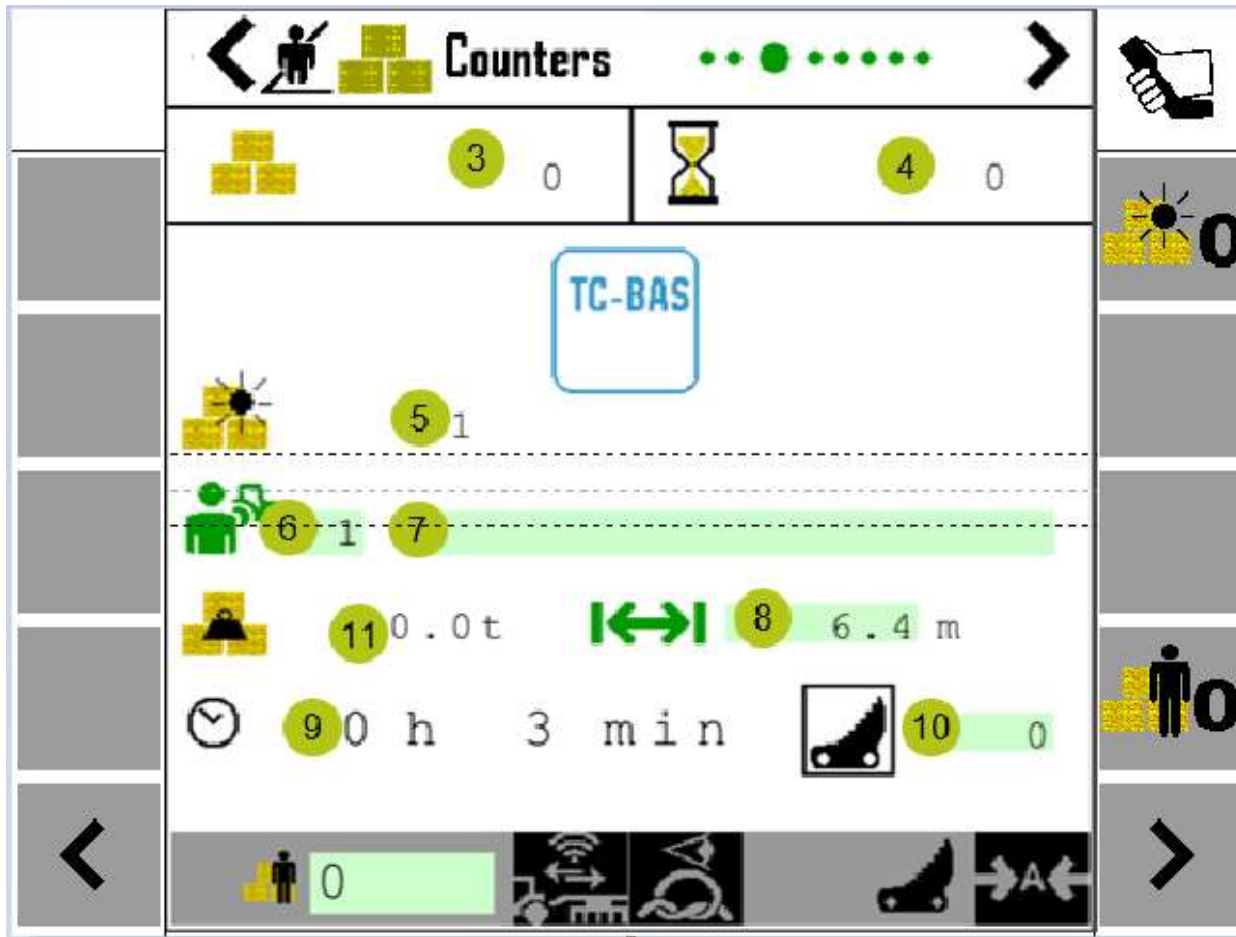
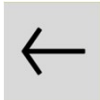

1. Set daily counter to 0
2. Set customer order to 0
3. Total bale count
4. Total hour meter
5. Daily bale count
6. Order no.
7. Order name
8. Baled bale length
9. Operating hours in order
10. Baled bales with cutting unit
11. Total bale weight per order

All data collected is transferred to ISOBUS/TELEMATIC

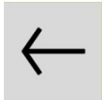

Operation – Fault Menu

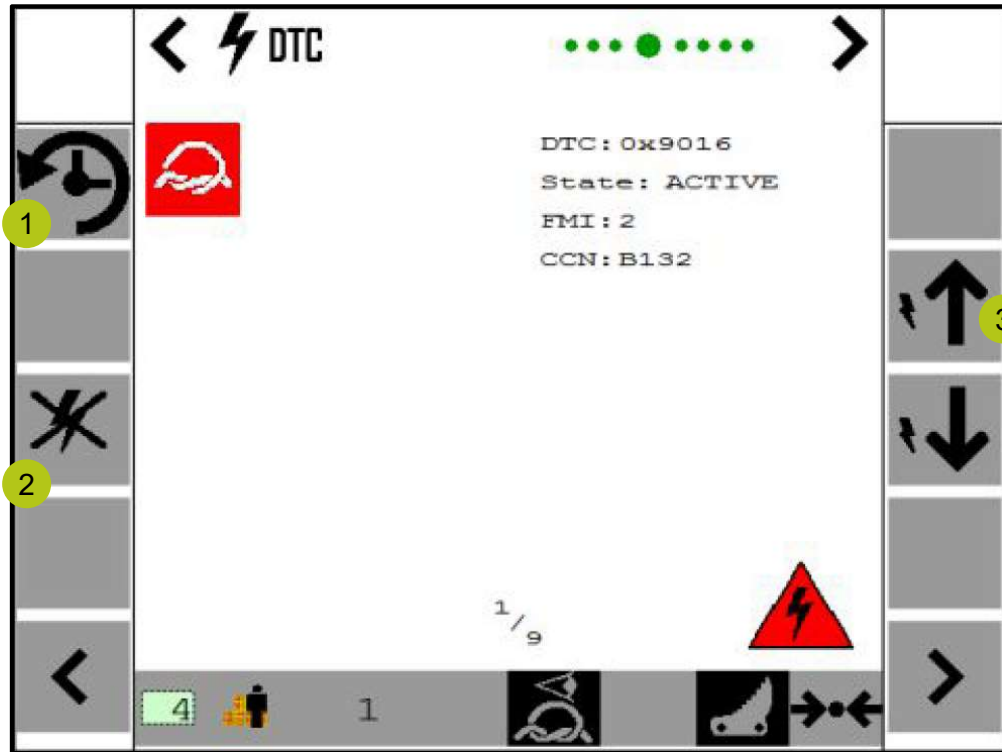

1. Display fault history
2. Reset fault message
3. Scroll through fault messages

Operation – Warning Menu

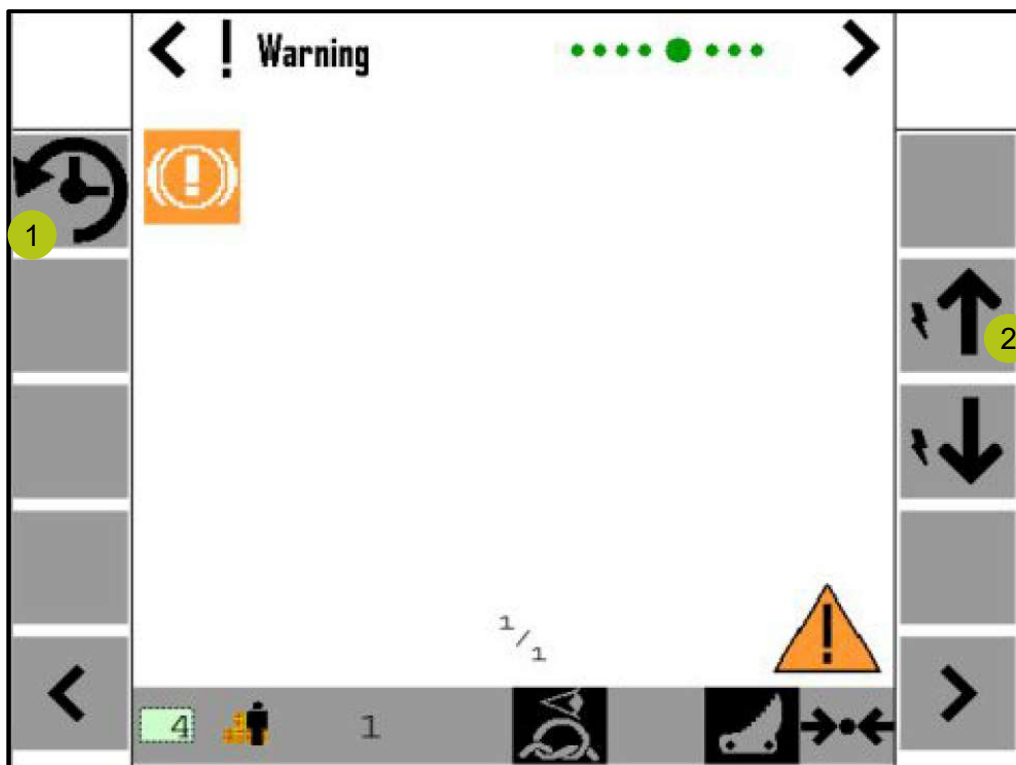

1. Display message history
2. Scroll through warning messages



Operation – Sensor Overview/Maintenance Menus

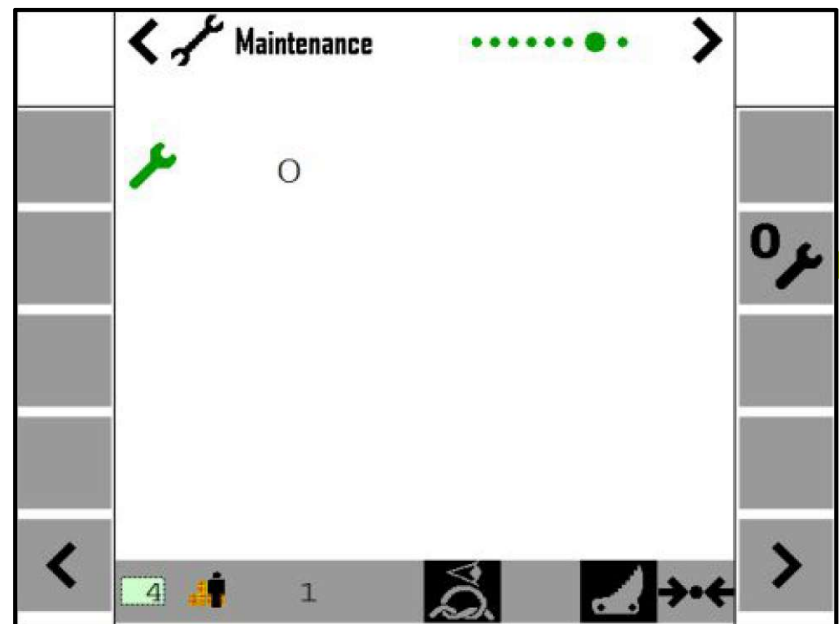
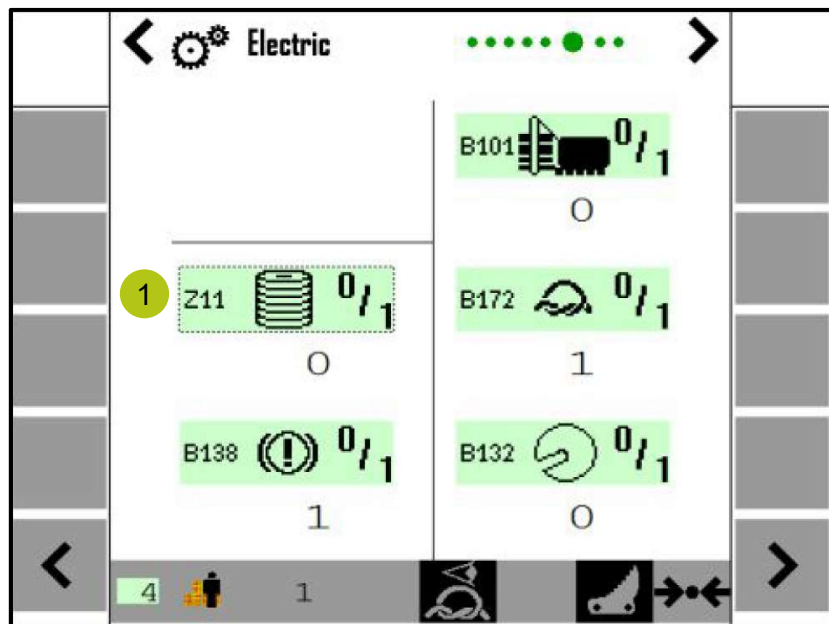

1. Selection of the sensor to be checked
2. Every sensor installed in the machine can be displayed here



Hitching

- Adjusting the drawbar for maximum baling capacity:
 - Place baler on level ground
 - Adjust hitch so that the pickup has maximum travel up and down without bottoming out on the rotor frame
 - Adjust hitch so that the knife drawer can be lowered fully without making contact with the ground
- Space the bolts (1) as far apart as possible
- Check the tightening torque of the screws (1) after the first 10 operating hours → See Operator's Manual!

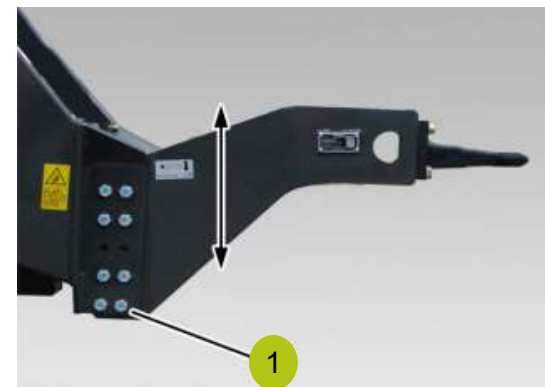
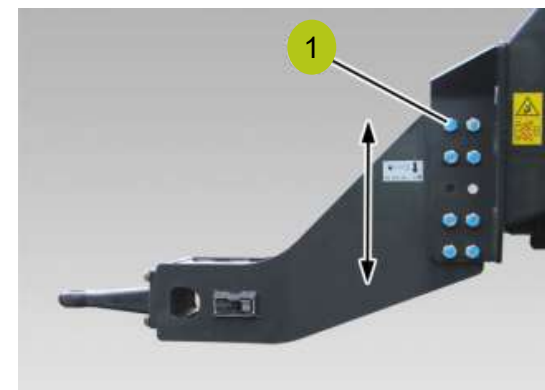



Hydraulic Connections

- Required tractor control units:
 - Baler: 1x single-acting control unit + unpressurised return or load sensing (**Optional**):
 - 1 x pressure connection
 - 1 x tank connection
 - 1 x LS signal connection
 - Pick-up and jack stand: 1 x single-acting control unit
 - Steering axle lock: 1 x single-acting control unit (**Optional**)
 - Flywheel brake: 1 x single-acting control unit (**Optional**)
- **Important: Unpressurised return should be guaranteed, but line reductions should also be avoided!**



Pick-Up and Jack Stand

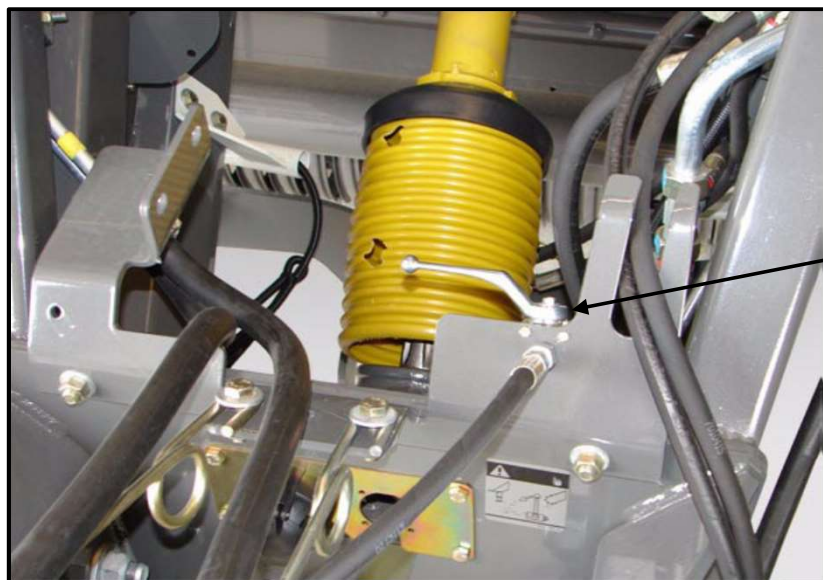

Actuation of the pick-up and jack stand are alternated via a three way valve. The valve is located above the PTO shaft transmission on the drawbar.

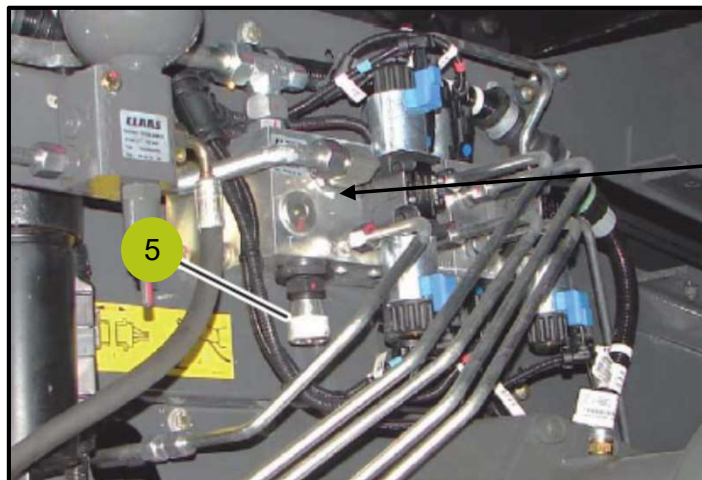

The baler can be operated either with constant flow hydraulics or load sensing hydraulics. For this, the main control unit must be adjusted with the system screw (5). The system screw is only available on machines without a hydraulic pick-up. See the Operator's Manual!



Friction Clutch

- The baler is protected against overload by a shear bolt in the friction clutch area.
- Screw: M10x50 10.9

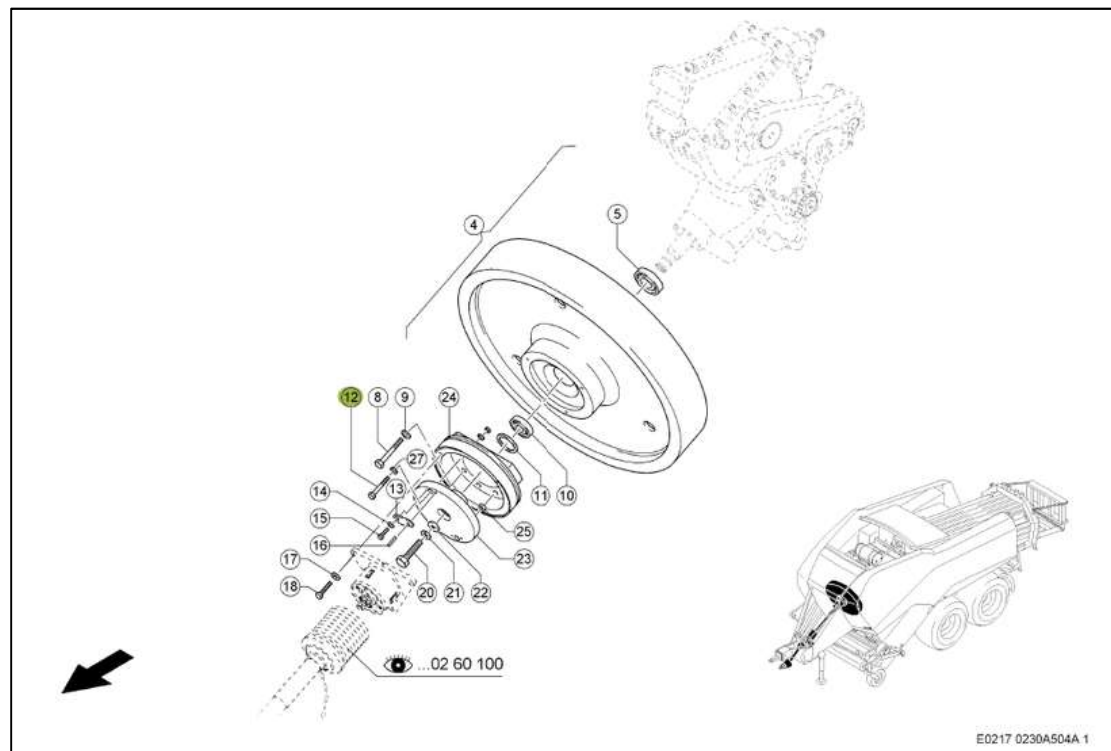
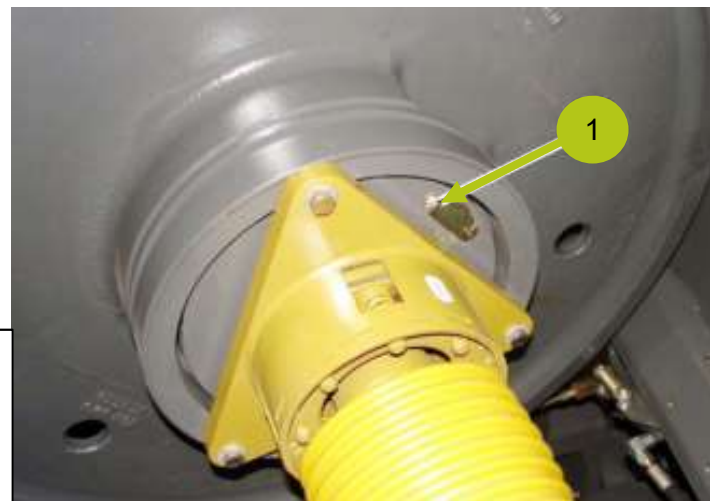



Flywheel

- Flywheel brake:
The flywheel brake (1) is tightened with the brake lever (2) for maintenance work.
- The hydraulic flywheel brake is available **as an option**. The cylinder (3) is actuated by the tractor's single-acting control unit. This enables fast braking when the PTO drive is switched off or if the rotor and feed rake tines are clogged. If the brake is applied, a symbol is displayed on the terminal by the sensor (5).
- **Caution: There is an overheat potential if the brake is not released or the brake band grinds against the flywheel. Check for a distance of 5-10 mm and adjust at the fork (4)! And switch the control unit to float position!**

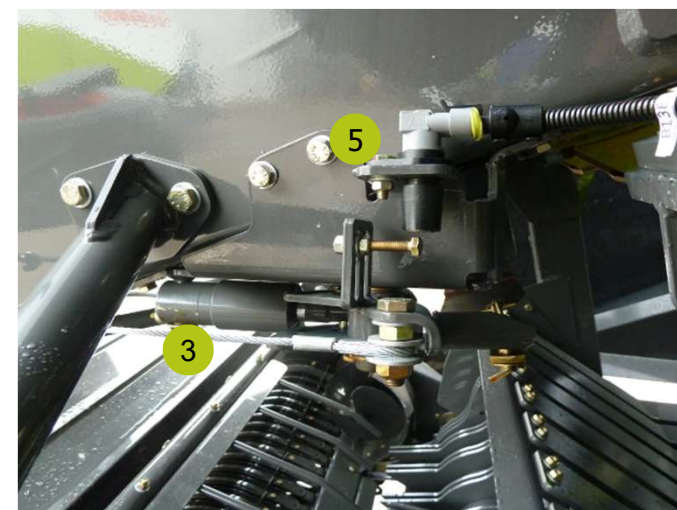
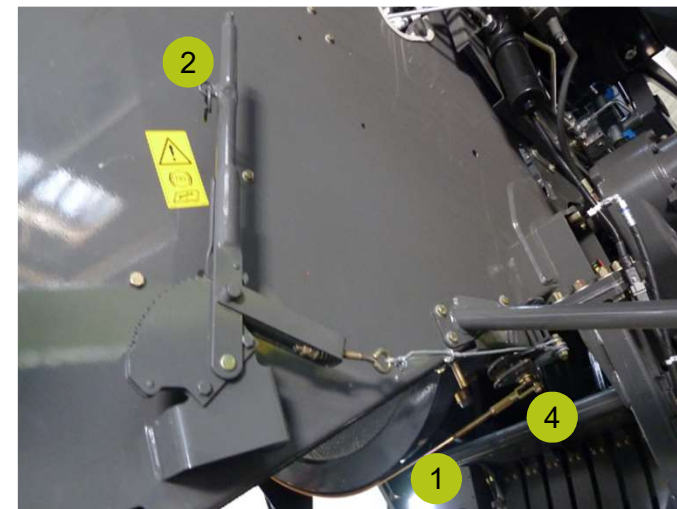



Pick-up

- Pick-up tines should be set approx. **1-1.5 in.** above the ground or just below the top of the stubble
- Adjust pick-up using holes **(1)** through **(7)**, where 1 is the lowest setting and 7 is the highest

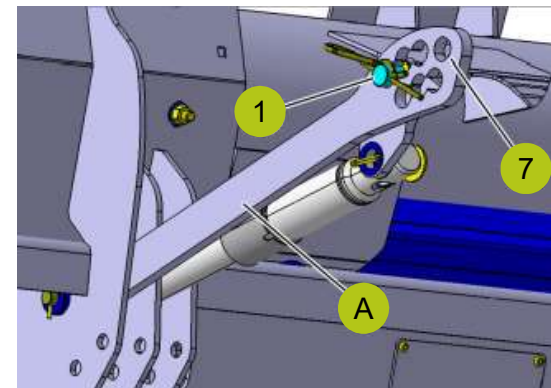

Crop	Item
Hay	1
Straw	2-7

- The pick-up gauge wheels are just guide wheels, they should not be load bearing in normal conditions. Set them just off the ground
- Adjust guage wheels via hole pattern **(2)**
- For transport or trucking the tires can be stored on the frame

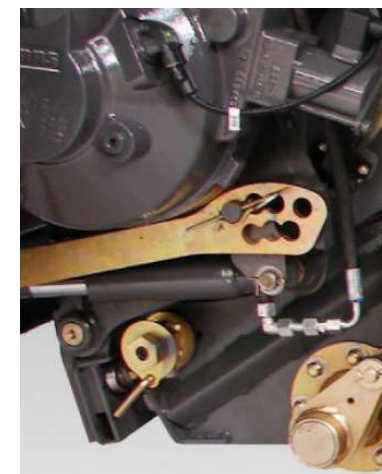



Pick-up/Feeding

- Crop feeding by pick-up with PFS:
After lowering the pick-up with pivoting gauge wheels, bring the tractor control unit to locked position again → Hydraulic pick-up load relief active (Do not run pick-up in float)
- Using the pick-up **without** pivoting gauge wheels (e.g. straw):
Bring the tractor control unit to neutral position

- Setting the springs on the roller crop press:
Silage: Spring at the top → Roller crop press lies loose on the material
Straw: Spring at the bottom → Roller crop press is pressed onto the material
Short straw: Both settings possible
- Depending on windrow thickness, the front roller of the roller crop press can be set in 2 positions **(3)**





Hydraulic Intake *OPTIONAL*

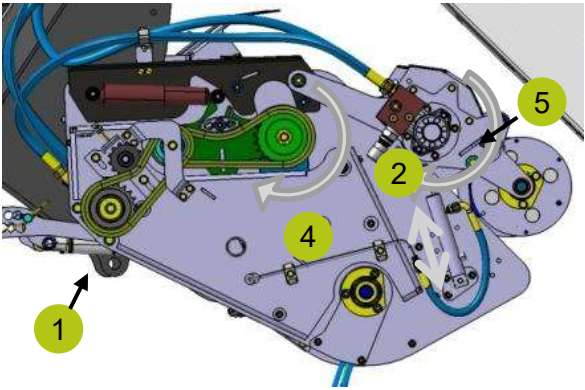

Working position

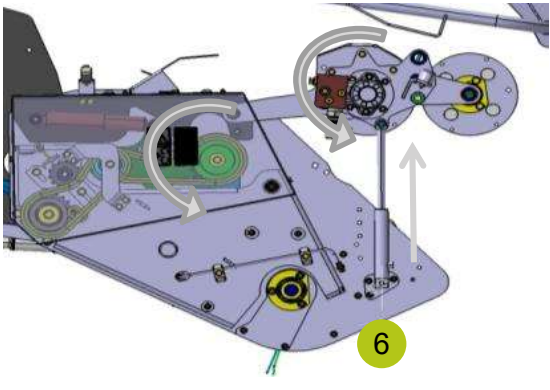

Reverse function



- Optional hydraulically driven pick-up (1), roller crop press (2) and PFS
- Speed can be adjusted in the Settings menu (3)
- **How it works:**
 - During operation, the pick-up and the roller crop press are driven, and the cylinders (6) of the roller crop press load relief are freely mobile.
 - If the feeder unit becomes overloaded, the unit can be reversed (100 rpm of the PFS auger).
 - At the same time, the roller crop press (5) is raised using the cylinder (6). The roller crop press and PFS rotate in the opposite direction to the feed and in doing so clear the pick-up.



Feed Systems

- **PFS: POWER FEEDING SYSTEM**
the additional auger (1) creates a smooth crop flow from the pick-up to the feeding/cutting rotor (2)
- The rotor transports the crop from the auger into the pre-chamber

- Rotor design:
4 rows of tines arranged in a spiral, diameter 50 cm, width 120 cm, Feeding and cutting function, additional strippers (3) prevent the crop from twisting
- Rotor drive:
The angle drive (4) transfers the torque through the driveshaft (5) to the rotor gear (6).

- **If overload occurs, the cam-type cut-out clutch in the rotor gear opens. This re-engages after the speed of the PTO shaft is lowered!**

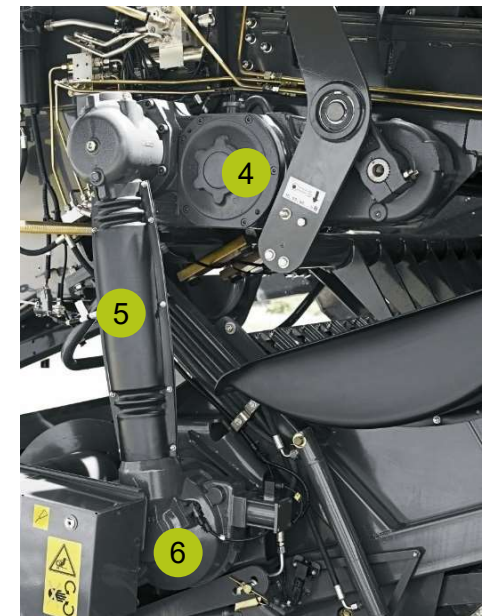
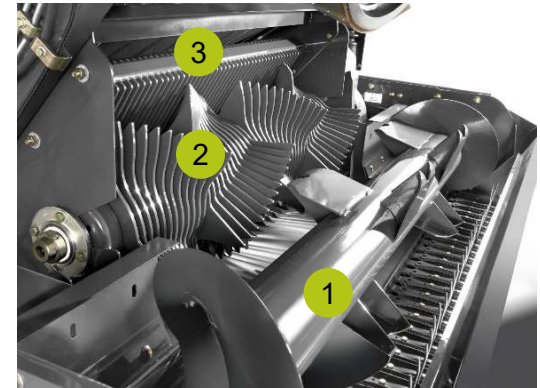

Cutting Unit



Design	Knife section	Min. theoretical cutting length
QUADRANT 5300 Roto Cut	0-12-13-25	1.75 in.
QUADRANT 5300 Fine Cut	0-12-13-26-51	0.88 in.

- To replace the knife, the drawer can be pulled out 60% to the left or right.
- **CAUTION:** The baler must be adapted to the tractor, so that the cutter chamber can be opened fully without making contact with the ground!

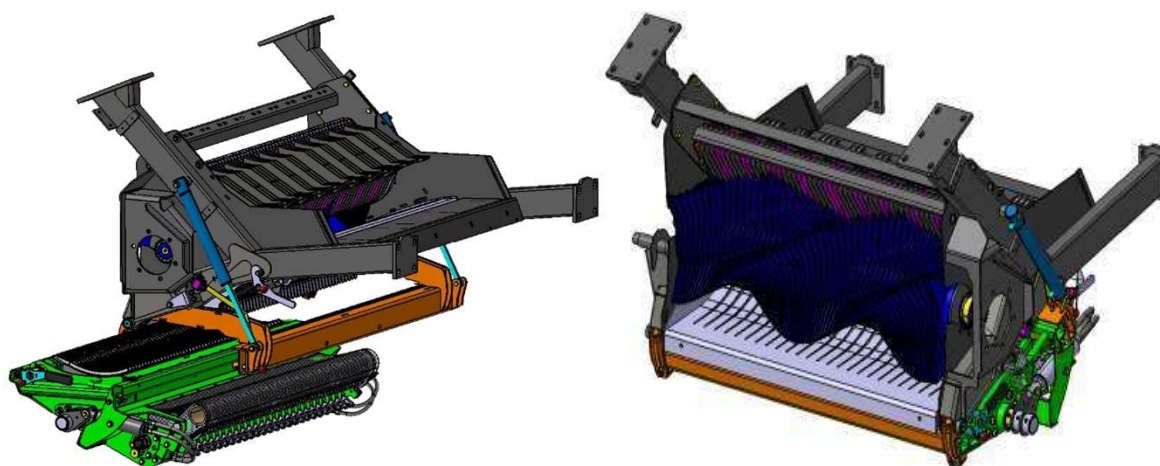

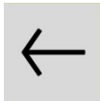

Knife Replacement Procedure

- To replace knives, lower the drawer and pull it to the left or right side to reach all knives. The drawer can be pulled out 60% in each direction.
- Procedure:
 1. Close the cutting frame completely → Turn selector switch **(A)** and selector switch **(B)** to the right
 2. Lock the trough with the lever **(4)**
 3. Lower the knife drawer
→ Turn selector switch **(A)** and selector switch **(B)** to the left
 4. Release the lock pin **(5)** to slide the drawer from side to side using handle **(6)** (**CAUTION if on a slope!**)

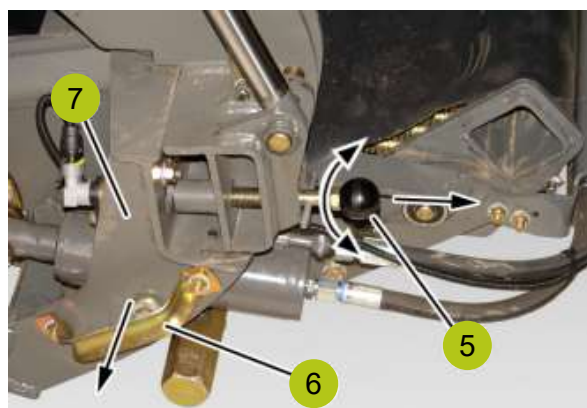
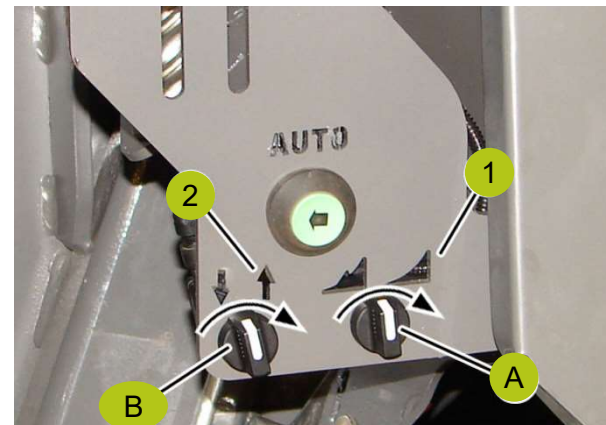



Knife Replacement Procedure

5. Unlock the knives using the lever (2)
6. Remove the old knife and clean the knife slot in the cutting frame
7. Insert a new knife and push onto the mounting shaft
8. Lock the knife using the lever (2)
9. Select the number of knives to be engaged by using the lever on the knife preselector (3) before engaging the knives in again. **CAUTION: Only turn in the direction of rotation and open the lock pin (4)!**

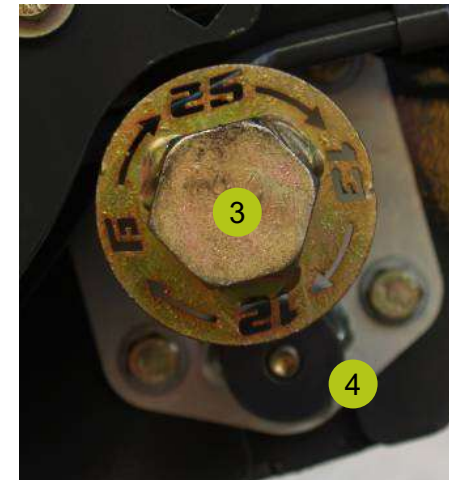
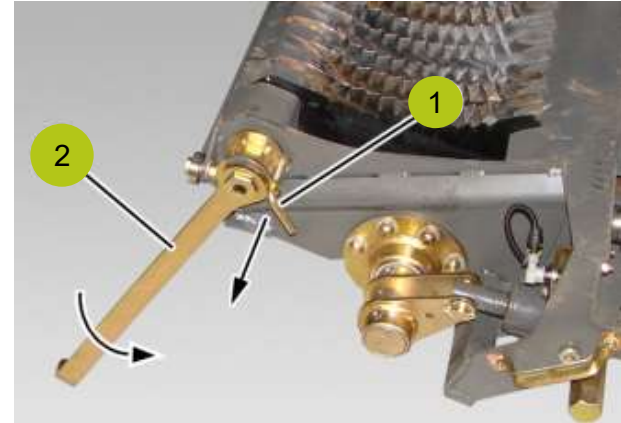



Knife Replacement Procedure

- Move the cutting frame back to working position.
- Procedure:
 1. Close the lock pin **(1)** of the drawer → If the drawer is not correctly locked, the sensor **(2)** does not detect any metal and the cutting unit cannot be moved to working position
 2. Close the cutting unit fully → Turn selector switch **(A)** and selector switch **(B)** to the right
 - Cutting frame moves up
 - The knives are swivelled out
 3. Unlock the trough with lever **(4)** for working position

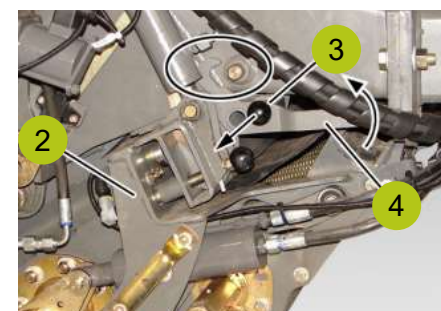
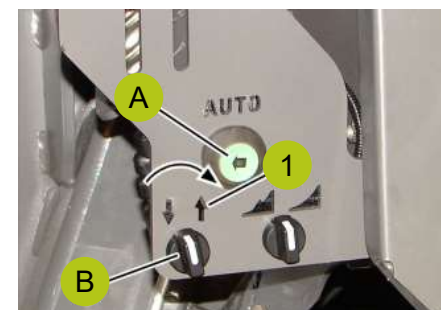
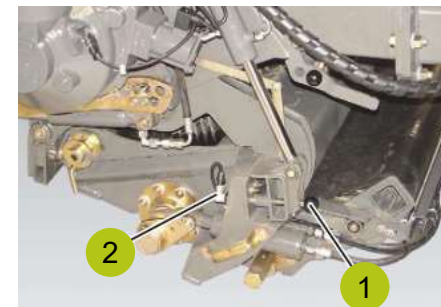

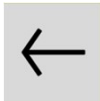

Cutting Unit

- Individual knife protection by spring clamp (1)
- When twisting the shaft for knife selection, different quantities of knives are swivelled into the crop flow
- The number of knives can only be changed with the springs swivelled out
- When using half of the knives, the knives in use should be varied daily, in order to ensure even wear
- When no knives are being used, blanking knives should be installed

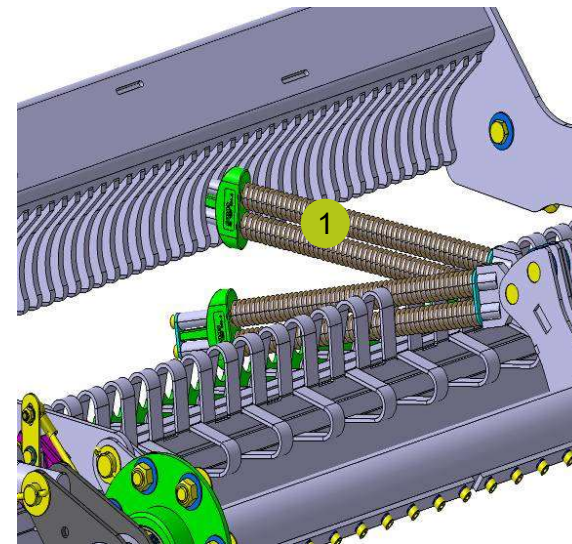
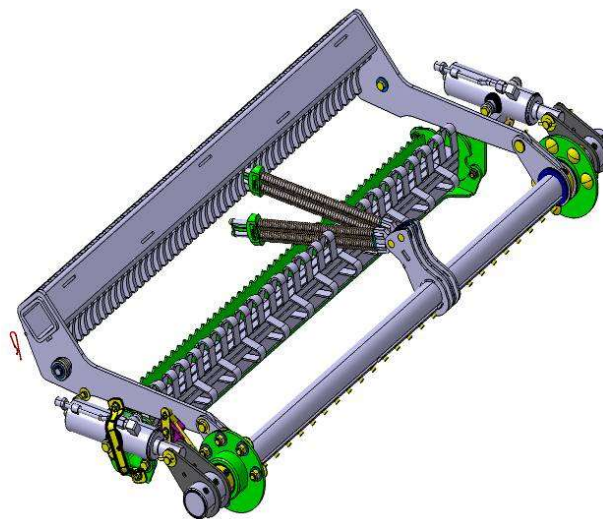

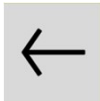

Pre-chamber

- Purpose of the pre-chamber:

Optimal filling of the bale chamber

- Two sensor bars (1) accurately sense the filling of the pre-chamber
 - Lower bar: hydraulically pressurized (3) (adjustable)
 - Upper bar: spring loaded (4)
- As soon as one of the sensor's two feed rake control bars is released (2), a filling stroke is executed by the feed rake control
- 3 pre-chamber settings depending on conditions

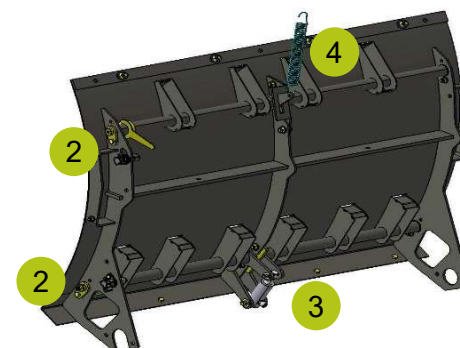
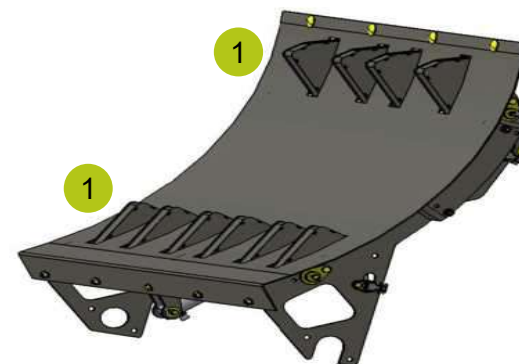

OFF



Large swath



Small swath



Pre-chamber

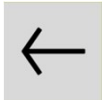

Pre-chamber off:



An alternating feed rake stroke followed by a filling stroke are executed

Large swath



With the large swath setting, the pre-chamber is only loosely filled. The ram can compact this material to achieve a high density.

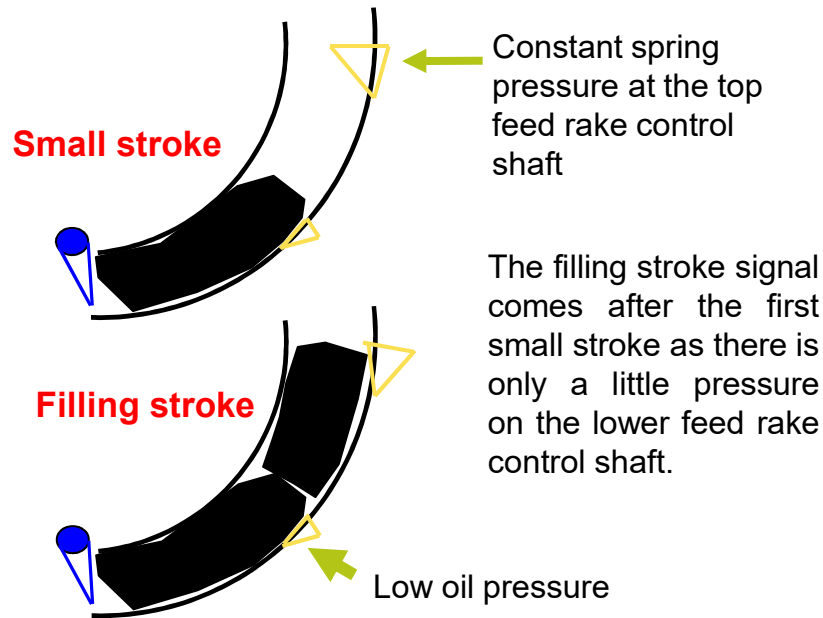

Small swath



With the small swath setting, the pre-chamber is filled more. The filling stroke fills the bale channel completely up to the top, resulting in optimum bale shape.

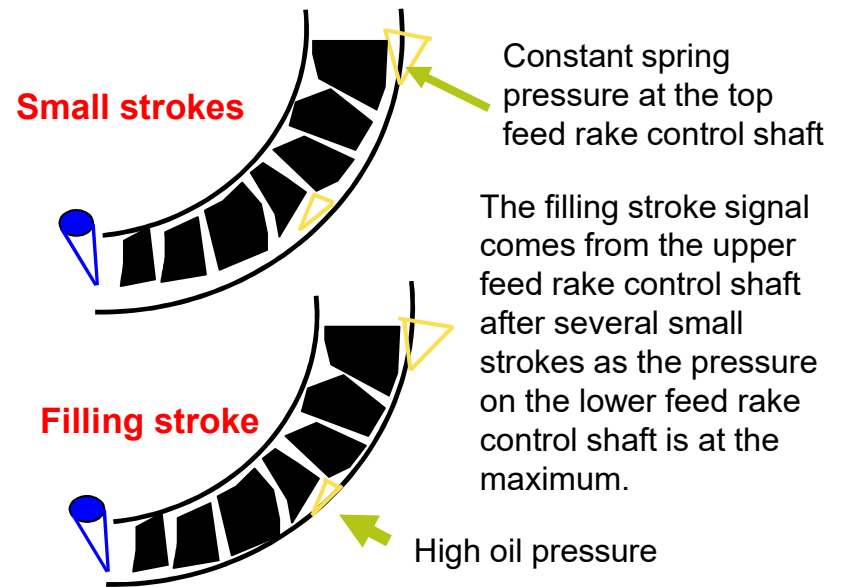



Feed Rake Control

- Ratio (1): Feed rake stroke: Filling stroke
- If the feed rake is overloaded, the rotor and pick-up are stopped (error symbol in terminal) → Lower the speed until the drives are secure again
- Check the oil levels (3, 4) in the feed rake gearbox
- If overload occurs, the cam-type cut-out clutch in the feed rake gear opens. This re-engages after the speed of the PTO shaft is lowered!
- CAUTION: After the feed rake clutch has engaged again, the speed must be lowered again to close the rotor clutch again.

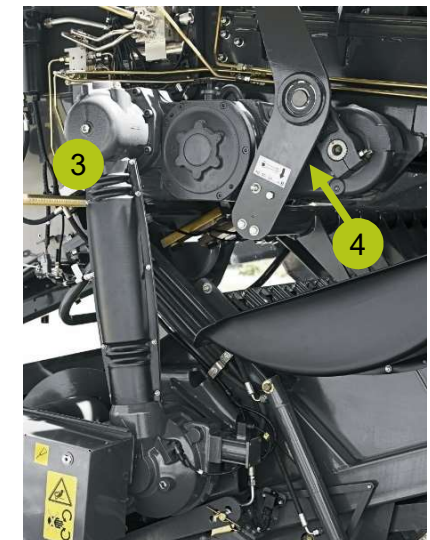
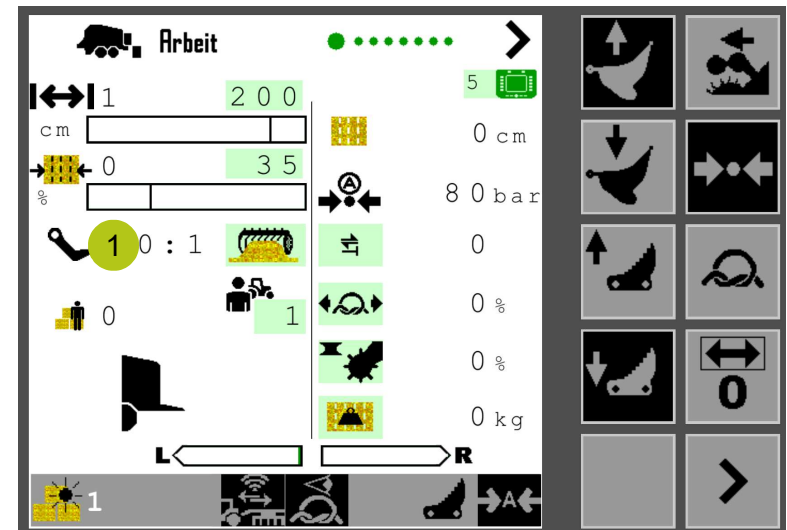



Plunger/Bale Chamber

- Check the plunger bearings → Ensure that the rollers (1) are supported on the track
 - Adjust using the eccentric bolt
 - **IMPORTANT:** Adjust the plastic stripper (2) to clean the roller track!
-
- The plunger knife (3) must be adjusted to the shear bar (4)
 - Release the shear bar (5) and adjust to dimension $x=3+1$ mm using the screws (6) on the blade (3)
 - In the case of wear, rotate the shear bar by 180° or replace it

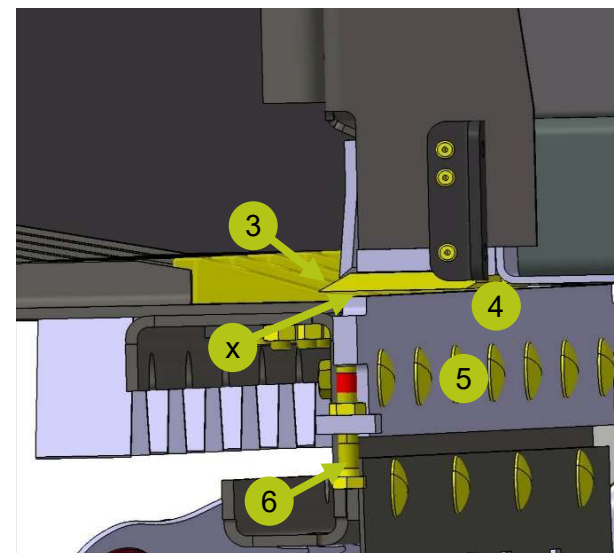
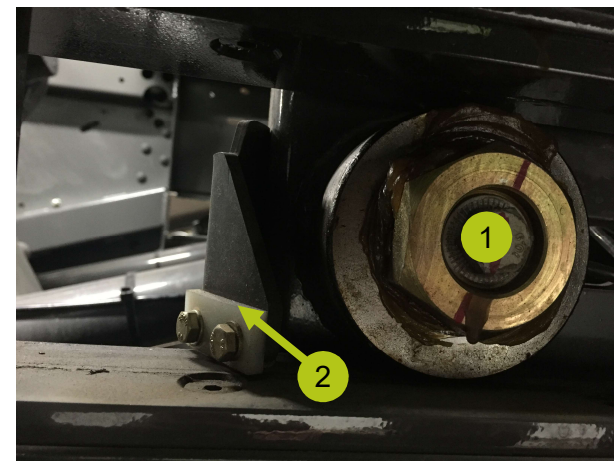



Plunger Load Indicator

- Based on the optional load indicator (1) for the baling plunger, the COMMUNICATOR shows the operator which side of the bale chamber is being filled more heavily with crop
- This is controlled via the 6 – Knotter monitoring.
- The L-R bar graph (1) changes with alternating load
- Meaning:
 - **Left** is displayed → More crop on the **left** in the chamber → Steer further to the **left**, then the pick-up will be filled more on the right
 - **Right** is displayed → More crop on the **right** in the chamber → Steer further to the **right**, then the pick-up will be filled more on the left
- If the machine is equipped with a load indicator, it also has the 6 – Knotter monitoring.

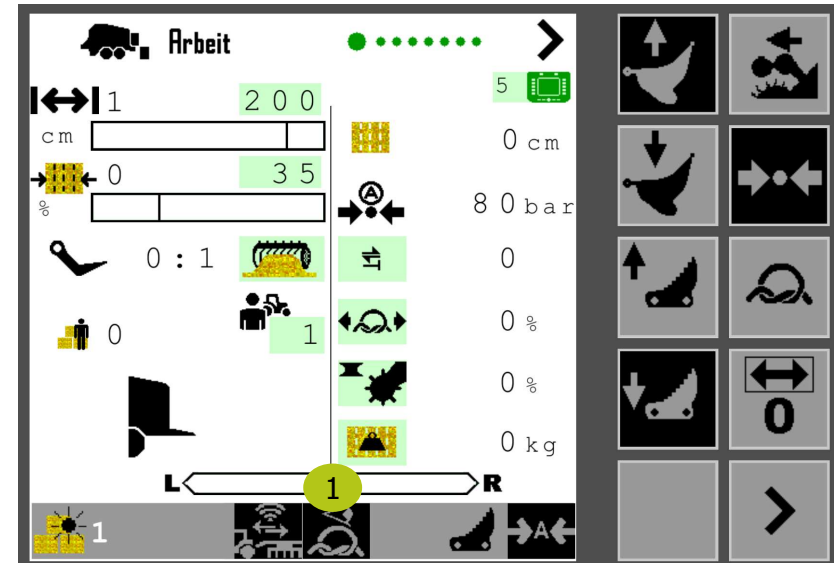

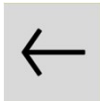

Baling Pressure Control

Baling pressure activation:

- Use key (2) on the terminal to build up the bale pressure
 - In manual mode, the bale pressure (4) can be set between 5 – 200 bar.
 - In automatic mode, the bale pressure is not set, but the bale density, from 10% to 100%. The bale pressure is set automatically → No information about the bale weight can be drawn from the bale pressure.
 - Symbol (5) shows the activated machine monitoring.
-
- When the first bales are compressed, the bale pressure should be reduced by 15-20%, as the paint on the chamber vanes slows the bales.
 - If a bale is compacted when the bale channel is empty, only minimal counter-pressure is available. Only the next bale can be used to check the actual bale density, as the counter-pressure in the bale channel can only build up now.

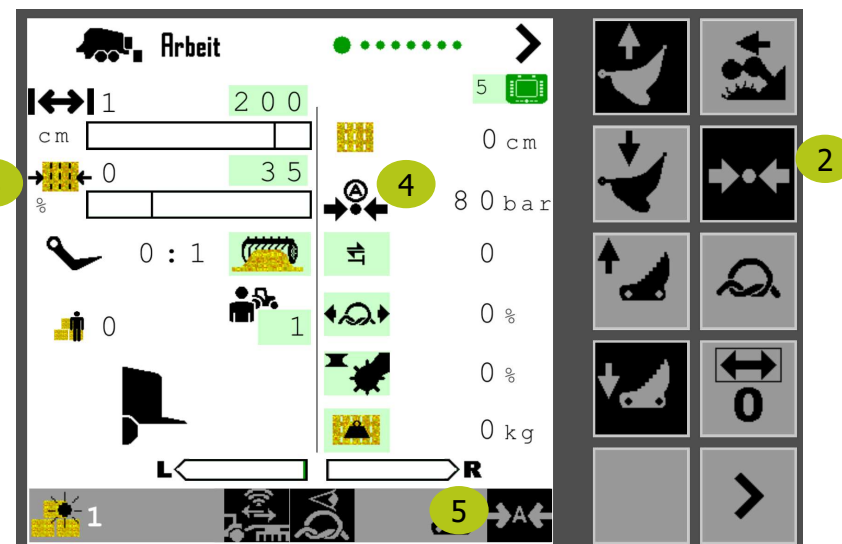



Tying Cycle

- The shortest tying operation can be implemented with a bale length of 0.5 m.
- The intermediate drive shaft **(2)** rotates constantly. The knotter shaft **(3)** rotates when a tying operation has been triggered with the mechanism **(4)**.

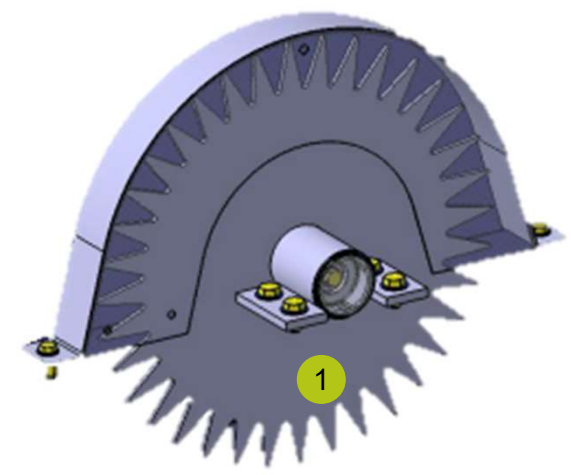

The shear bolt **(5)** protects against overload.

- Problems in the knotter area?
- Foreign objects?
- Knotter condition?

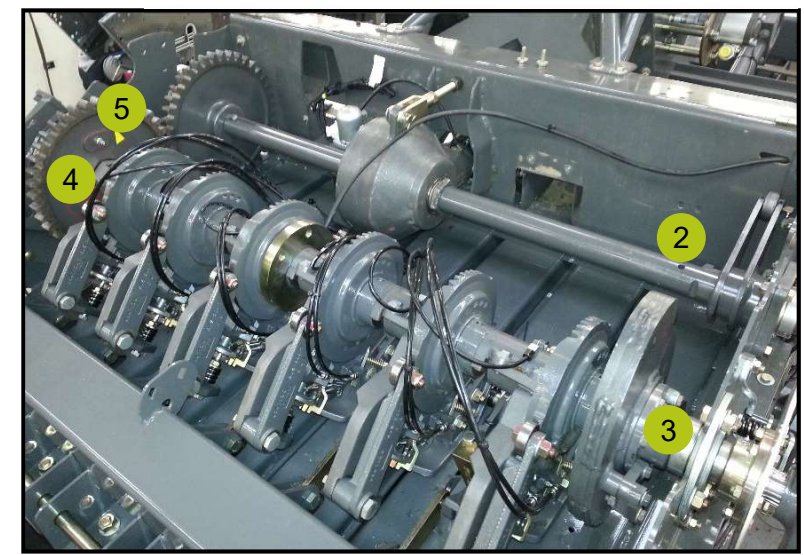
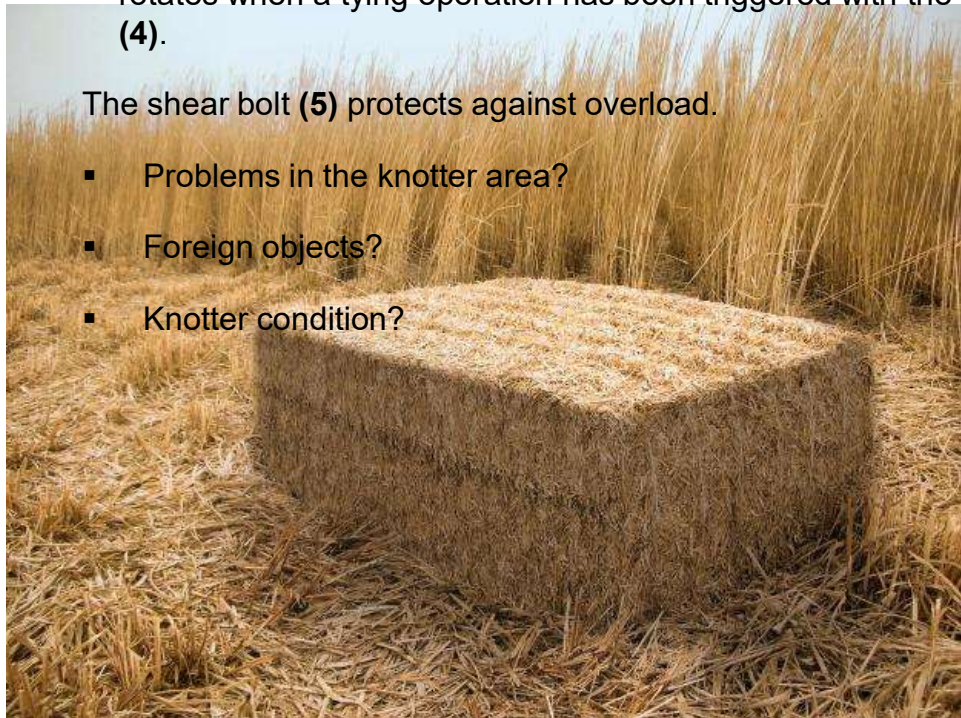

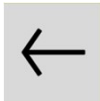

Knotter

- 1. Twine retaining pinion
- 2. Twine retaining plate spring
- 3. Twine retaining plate
- 4. Twine feeder
- 5. Knotter base plate
- 6. Knotter bill hook pinion
- 7. Knotter bill hook spring
- 8. Knotter bill hook tappet
- 9. Knotter bill hook
- 10. Knives
- 11. Twine retainer wheel



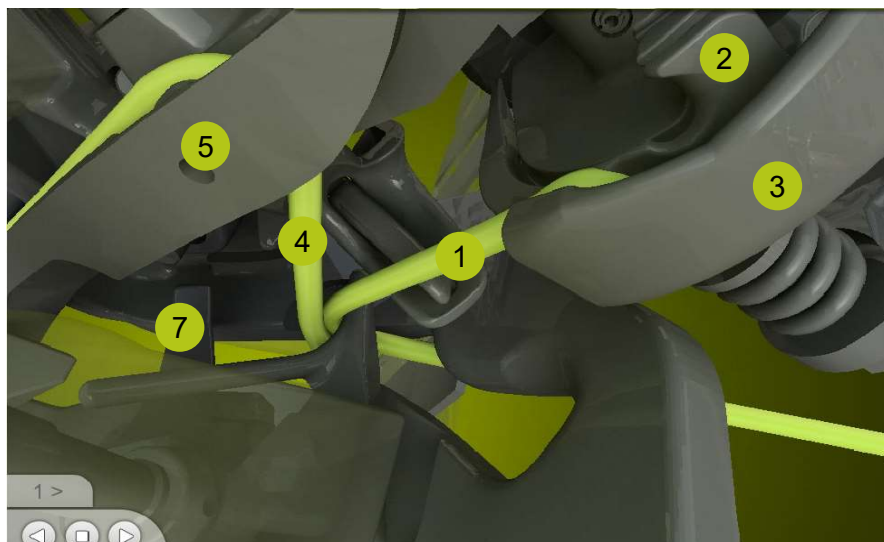

- The twine placed around the bales is held on the one side **(1)** between the clamping wheel **(2)** and the retainer plate **(3)**.
- The other side **(4)** runs through the eye of the needle **(5)** to the roll of twine.
- Once the tying process has been triggered, the needle guides in the twine **(4)** to the knotter, protected by the baling ram. Both ends of the twine are now on the knotter bill hook **(6)**.
- During the knotting process, the twine retainer **(7)** holds both ends of the twine together.
- The twine retainer now moves twice per tying cycle and is closed in the rest position.

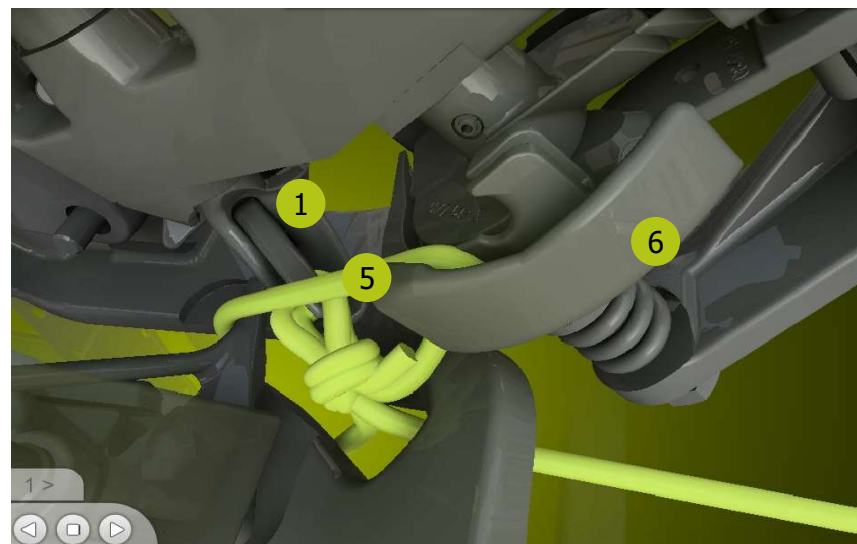
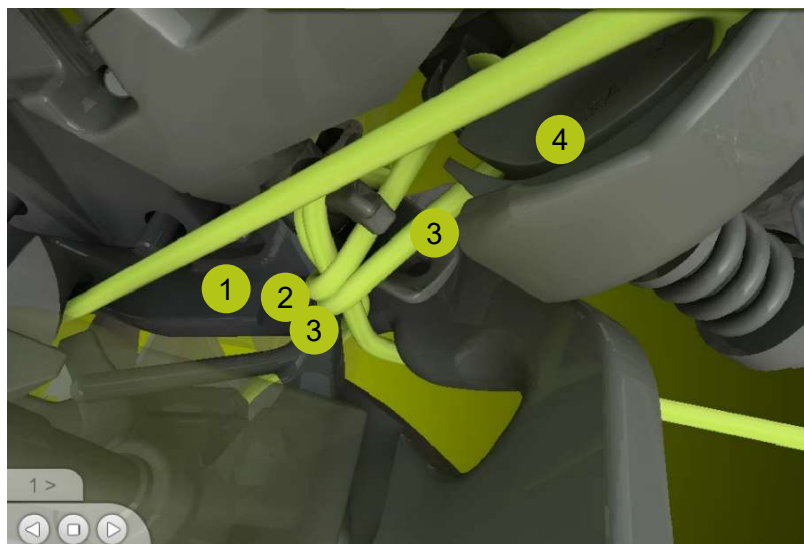

- The knotter bill hook **(1)** turns around its own axis with both ends of the twine **(2,3)** to make a loop. Shortly before the knotter bill hook returns to its initial position, the knotter jaw opens and catches the twine pair at the end of the loop.
- Meanwhile, the clamping wheel **(4)** turns and cuts the twine **(3)** on the knife section. This creates a new twine end **(5)**, which is held under the retainer plate **(6)** for the next bale.
- The original twine end **(2)** is released from the retainer plate **(6)** by the gradual turning of the clamping wheel **(4)**. The movement of the crop will close the loop at the knotter bill hook **(1)**.
- Finally, the knot is pulled off from the knotter bill hook **(1)** as the bale moves further out of the machine. During this time, the needle has already moved back to its initial position.



Twine Guides

The twine guide and brake on the QUADRANT are implemented via 2 elements:

- Twine brake **(1)**: ensures twine remains taut during the knotting process → Theoretical spring length to be set for the brake without twine $x = 58^{-1} mm$
- Twine tension spring **(2)**: Twine buffer for jerky start to the tying operation → The twine brake **(1)** should be set taut enough that the tension spring lifts by approx. 50 mm from the contact switch **(3)** when idle. A fault message is displayed on the terminal if the twine breaks.

IMPORTANT: The twine brakes must generally be adjusted to the twine! The thinner the twine, the greater the required spring pretension.

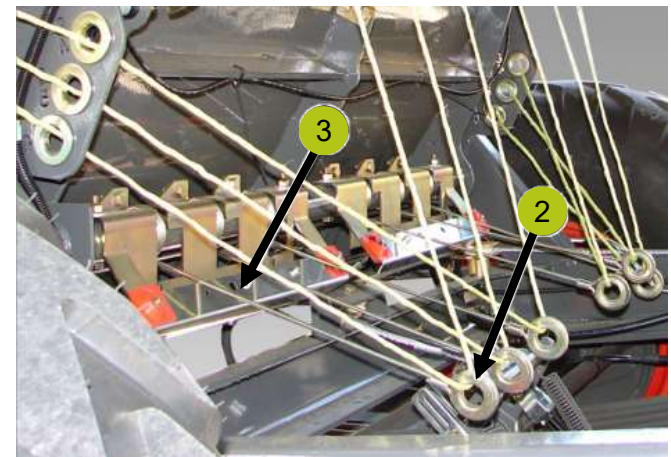

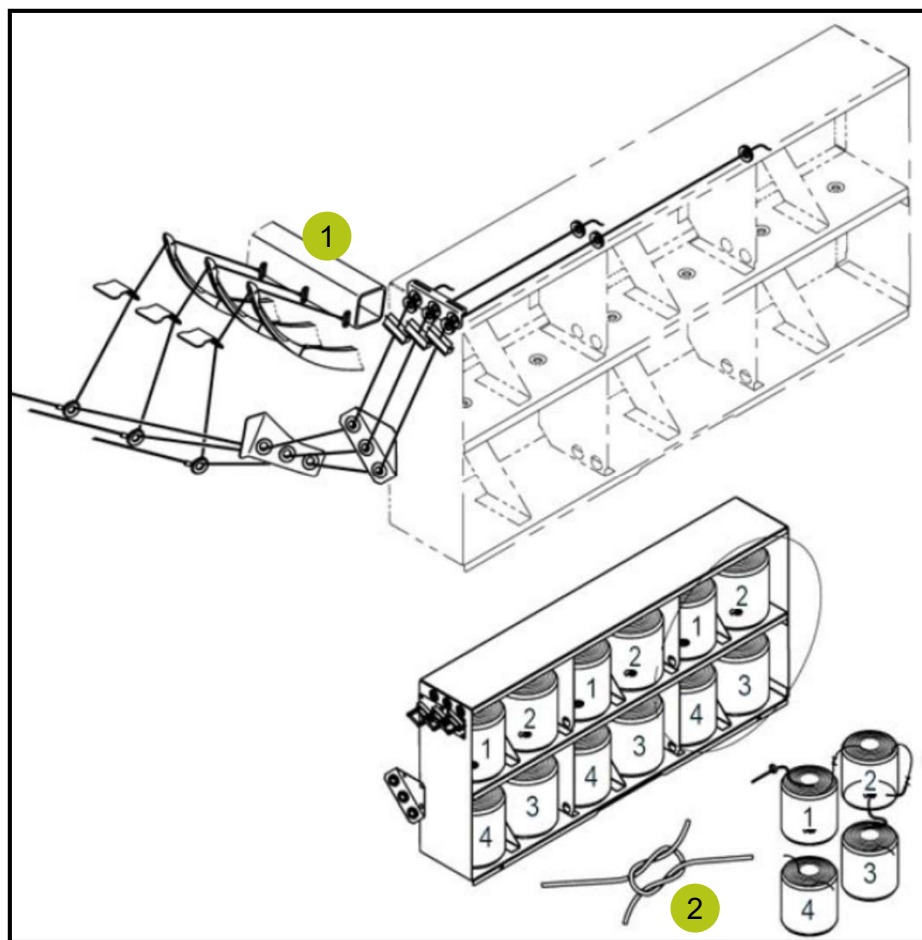

Inserting the twine:

- Pull the twine through the eyelets as shown in the diagram, and tie it firmly to the frame **(1)**.
- Tie the twine rolls together in the following order: 1- 2- 3.
- Do not tie roll 4 → Spare roll

Knotting:

- The twine ends should be tied with a knot as small as possible **(2)** as this knot also runs through the eye of the needle, which is narrow.
- Leave the twine ends with an overlap of approx. 15 to 20 mm.

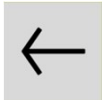

Bale Ejector

The bale ejector **(1)** in the bale channel is moved by a hydraulic cylinder and consists of:

- 4 tines **(2)** which are permanently in operation during actuation
- The front 4 tines **(3)**, which can be used after manual start-up

Use of the min. or max. usable tines:

- Ejecting the last bale in the bale channel → only tines **(2)**
- Ejecting all the material in the bale channel → tines **(2)** + **(3)** are activated

IMPORTANT: Activate the tines (3) only when the tractor is switched off!

Switch between the hydraulic function of the bale ejector and the bale ramp via the switching valve **(4)**. In Pos. direction **(4)**, the bale ejector is actuated and the bale channel is emptied. Continuous operation of key **(5)** as well as key **(6)** determines the direction of movement of the bale ejector. **Two-handed operation!!! → Reactivation of the bale pressure in the COMMUNICATOR!!!**

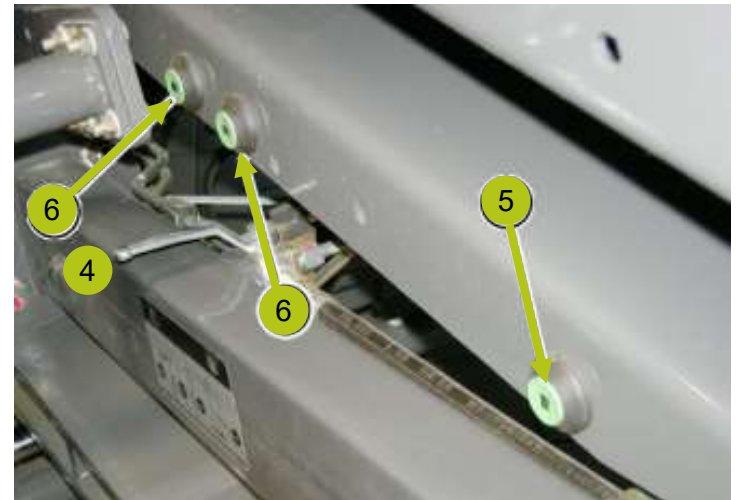
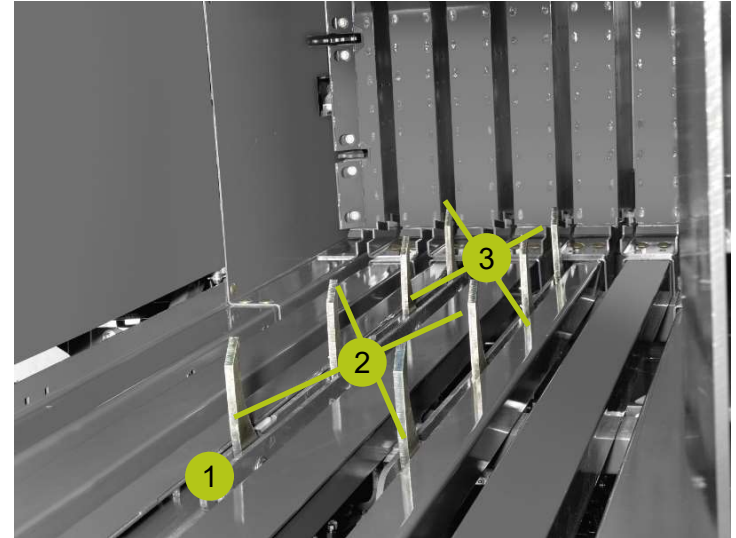

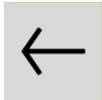

Bale Ramp

The bale ramp is actuated by the double-acting cylinder (6). The lock-up valve unit (7) prevents automatic dropping. The angle sensor (8) transmits the position of the bale ramp to the terminal (9).

- Place the switching valve (4) in position (1) (**IMPORTANT: Position for baler operation!!!**)
- Raise the bale ramp → Press and hold key (2) as well as key (5)
- Lower the bale ramp → Press and hold key (2) as well as key (3)

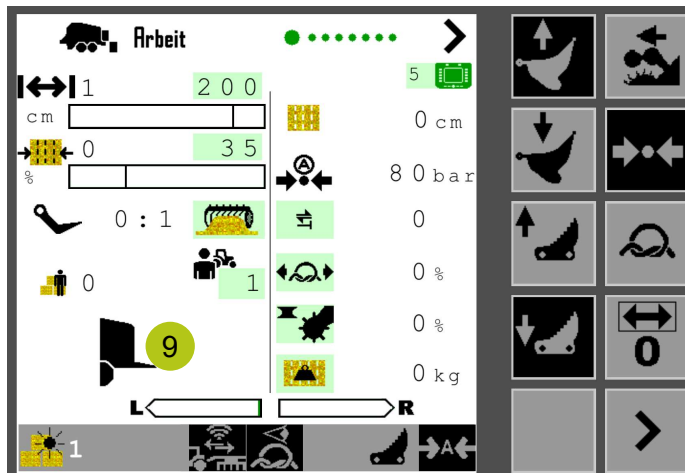
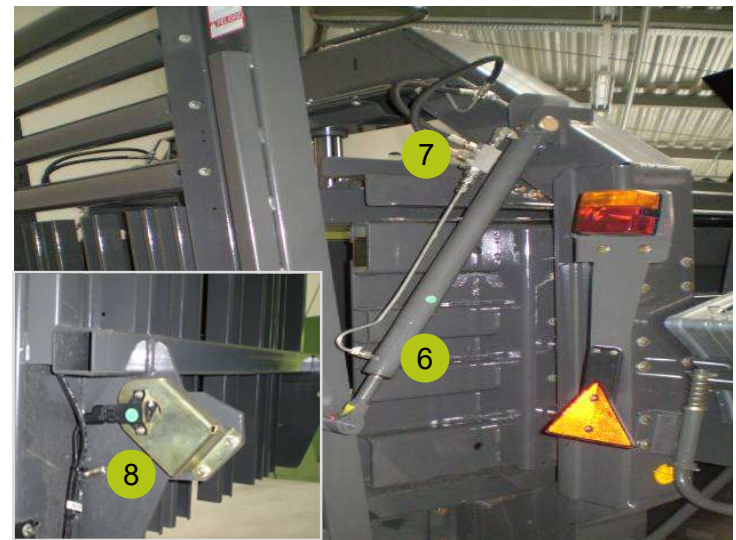
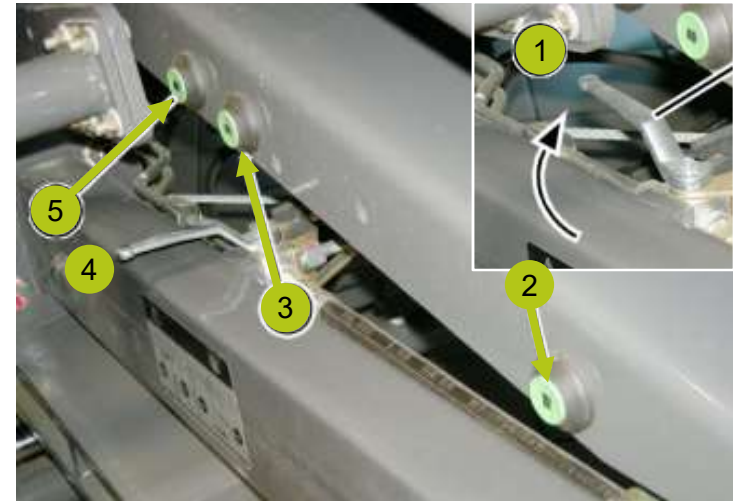



Bale Scales (optional)

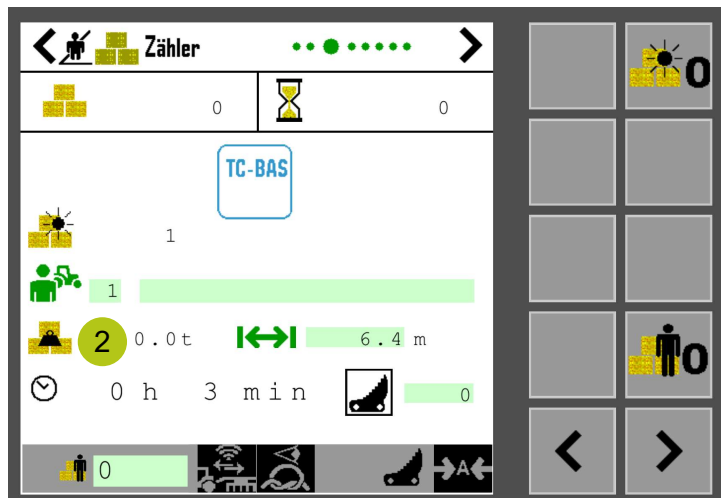
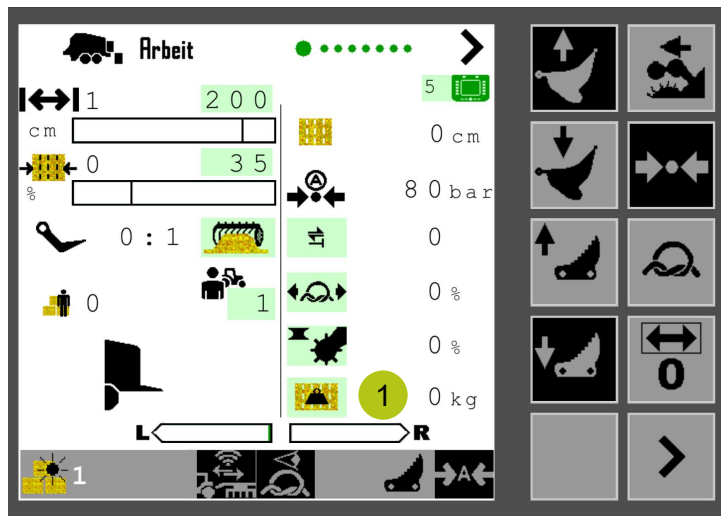

- The weight of the bales is determined via four weighing cells on the bale chute.
- The weight of each individual bale is displayed in the Working menu **(1)**.
- The total of the weights is added together in the Orders menu **(2)** and saved for each order.
- The bale weights are stored on an ISOXML basis and, like all other data, can be accessed in the ISOBUS terminal via the documentation option.
- The data can be transferred online in conjunction with TELEMATIC.



Central Lubrication System

- Lubrication **(1)** is active as soon as the main drive is in operation
- The pause time **(2)** can be set between 2 to 10 minutes. The lubrication interval is 10 minutes.
- Regularly lubricate the areas that are not supplied by the central lubrication system → Check lubrication chart according to Operator's Manual
- Manual lubrication by pressing key **(3)**
- Filling should only be implemented via the grease nipple or plug **(4)**, to prevent the ingress of dirt.

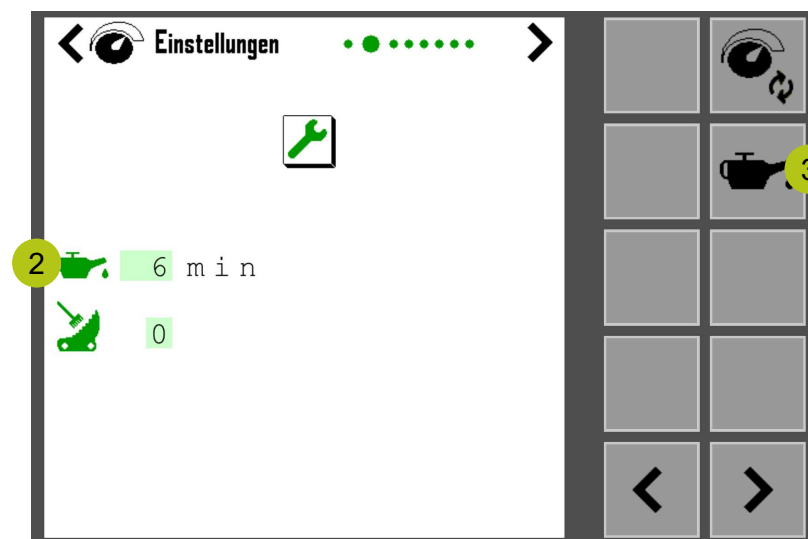
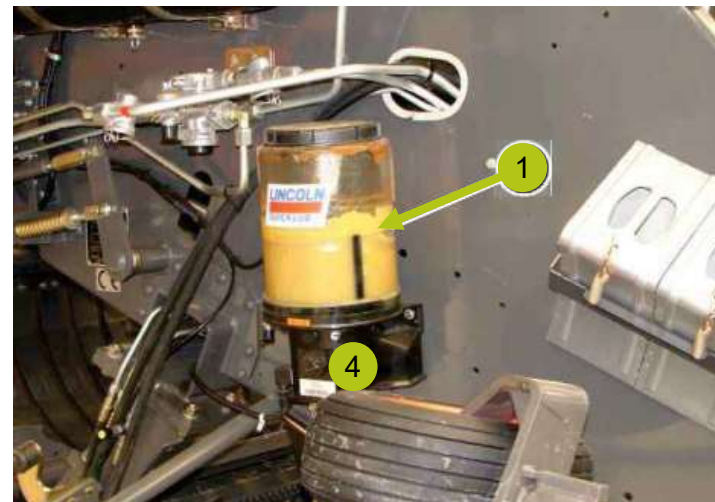

TURBOFAN

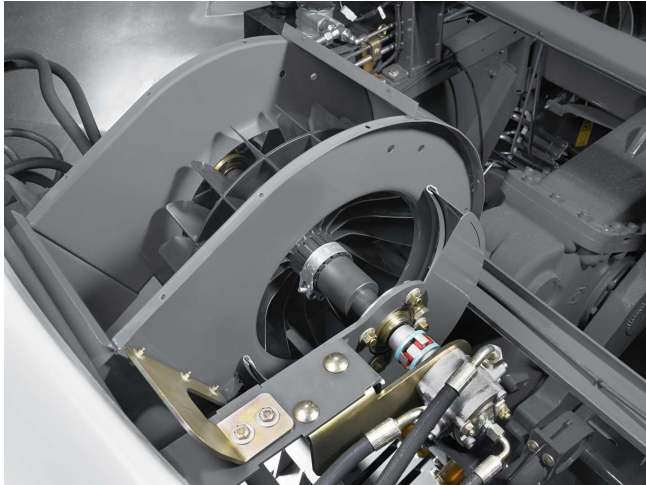

- Continuous cleaning of the knotter and bale channel
- Wind speed up to 120 km/h

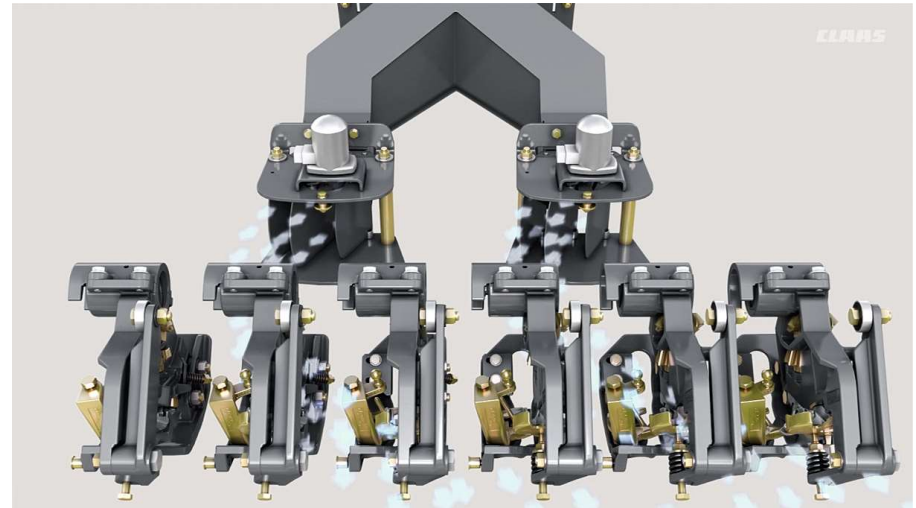
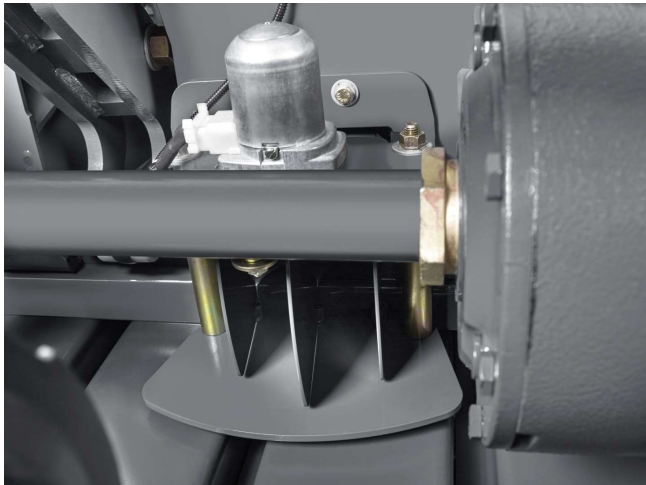



Steering Axle/Chassis (optional)

- A single-acting control valve on the tractor is used to switch between "run on" and "fixed".
- If the run on axis is fixed, the ball valve (1) can be unlocked to prevent a possible pressure loss. The same applies when decoupling the baler.
- **IMPORTANT:** Tighten the wheel nuts after the first operating hours!

Use	Position
On the field	Run on
Driving on public roads	Fixed
Reversing	Fixed
Working in difficult conditions	Fixed





Moisture Sensor (optional)

Using the optional bale moisture measurement (1), the operator can adapt the bale pressure to the respective crop (damp: lower bale pressure, dry: higher bale pressure)

- The value shown (4) is a guide value and not a calibrated measurement reading
- The value shown is only an instantaneous value → The display must be monitored over a long time
- The moisture level is determined based on the resistance between the contact plate (2) and the contact (3)
- **IMPORTANT:** The operator must use a bale moisture measurement during operation to determine the actual bale moisture levels, in order to be able to interpret the values on the display!

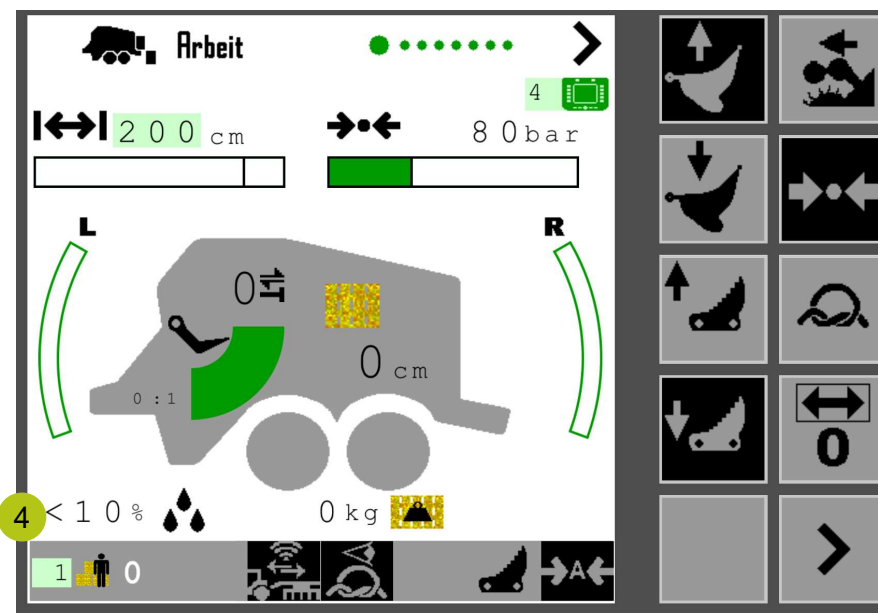
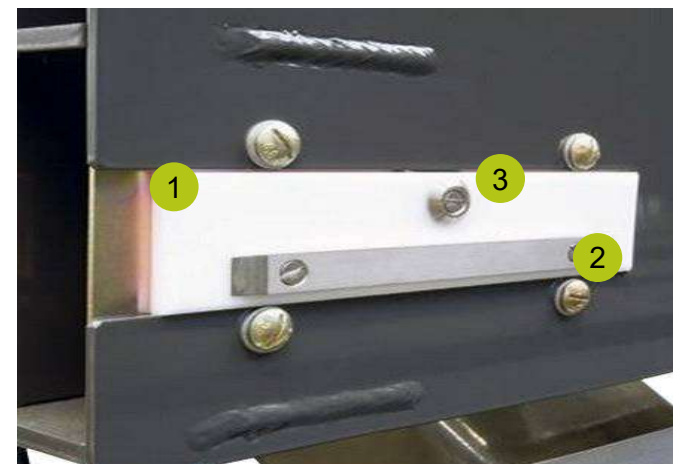

Cornstalk Equipment

Maize equipment

The perforated plate (1) is standard and should be used for baling cornstalks. Soil can fall through this plate. Extensions (2) are fitted to the plunger as standard. These cause the bale to be pushed further forward, reducing the likelihood of the twine rubbing against sharp cornstalks. In addition, the baling pressure can be considerably reduced when baling cornstalks.

