

SPUDNIK

6160^{S4} Windrower QUICK START GUIDE



Table of Contents

Safety	1
Operator Responsibilities	1
STEP 1: Meet the Windrower	2
Theory of Operation	2
STEP 2: Make Connections	3
Connecting the Windrower to the Tractor	4
Mechanical Connections	4
Hydraulic Connections	6
Electrical Connections	6
STEP 3: Perform Pre-Run Setup	11
Button Assignments	12
Joystick Mapping	16
Start/End of Row Setup	18
STEP 4: Understand Controls	21
Operating Controls	21
Introduction to the CX3 Controller	21
STEP 5: Operate the Windrower	25
Custom Settings	25
Creating a Setpoint	26
Ridge Relief	27
Setting Ridge Relief Pressure	28
Digger Control	29
Depth Wheel Depth Control	31
Primary Chain Drive	33
Primary Chain Hydraulic Reverse Option	33
Alarm Display	34

IMPORTANT

This Quick Start Guide documents the operation of software version S4D 2.06 with controls set to the default position. Depending on the software version and control installation location, actual operation may differ. Confirm the installed software matches the documented software.

Safety

Operator Responsibilities

This Quick Start Guide is intended to familiarize the operator with basic safety information, operational responsibilities, implement connectivity, and implement controls. For additional information, scan the QR code on the back cover of this guide, or visit:

<https://documentation.spudnik.com/6160Windrower>

The operator is responsible for their own safety and for the safety of others working on or in proximity to the windrower. To ensure everyone's safety, the operator must maintain situational awareness at all times. This requires the operator to understand the operational controls of the windrower and to be familiar enough with the controls that their use is instinctual. With this level of competence, the operator can focus their attention on workers, the windrower, and operating conditions.

Training: Before the initial startup of the windrower, perform a safety briefing for all personnel assigned to work on or in proximity to the windrower. This section identifies minimum safety considerations to be trained before allowing anyone to work on or around the windrower.

Warnings/Notices: Warning signs and notices are placed on the windrower to warn of potential hazards and to provide information for safe operation. The operator is responsible for complying with all safety notices and for instructing workers to do the same.

Shields: Shields are an engineered safety barrier designed to keep individuals away from dangerous moving parts. While it may be necessary to remove shields to perform maintenance or repairs, never operate the windrower unless all shields are secured in position.

Worker Approved/Prohibited Locations: The primary worker approved location is the operator station, specifically the driver's seat of the tractor connected to the windrower. All other areas of the windrower are off limits to worker access while the windrower is in operation.

Clothing: All workers should wear snug fitting clothing. Loose clothing or personal belongings such as fanny packs, knapsacks, etc., can be caught and pulled into the moving parts of the windrower, resulting in serious injury or death.

Maintenance/Repair: Maintenance or repair work on the windrower should be performed only by properly qualified and trained personnel. This includes work on the mechanical, electrical/electronic, and hydraulic systems.

Preventative Maintenance: For daily and other periodic maintenance information, refer to the *Maintenance Guidelines* sticker located on the windrower drawbar. To ensure ongoing safe operation of the windrower, the operator must ensure that scheduled maintenance is performed prior to the operation of the windrower.

Prestart Warning: Before turning on the drive, operating any of the hydraulic systems, or moving the windrower, the operator is responsible to check on and around the windrower to make sure all individuals are clear of moving parts and have been alerted that operation is imminent.

Operating Environment: As part of the necessary situational awareness, the operator must take into consideration the weight, length, and width of the windrower. Be aware of the side overhangs and the additional clearance they require. Clearance is particularly critical when turning or backing the windrower. Always match the ground speed to the prevailing conditions, both in the field and when towing the windrower on roads. Pay attention to stopping distance at varying speeds and conditions. Do not overdrive the braking capabilities of the towing vehicle.

STEP 1: Meet the Windrower

Objective: Introduce the operator to the basic components and physical layout of the Spudnik 6160^{S4} Windrower.

Theory of Operation

The basic components and physical layout of the windrower are designed to efficiently and consistently dig potatoes while minimizing product damage and waste. (see [Info](#) and [Figure 1](#))

The Spudnik 6160^{S4} Windrower is designed for high-capacity potato harvesting operations. The function of the 6160^{S4} Windrower is to dig six rows of potatoes, separate the product from soil and debris, and deliver the product into the furrow(s) between undug rows, for the harvester to pick up.

At the front of the windrower, the (1) Digger Nose lifts potatoes from the ground and deposits them onto the (2) Primary Chain. The Primary Chain provides initial cleaning while transporting the potatoes to the (3) Secondary Chain and (4) Vine Chain. As the potatoes drop through the Vine Chain onto the Secondary Chain, the vines are left on the Vine Chain and carried to the rear of the machine, where they fall back to the ground. The potatoes continue from the Secondary Chain onto the (5) Rear Cross Chain. Depending on the options installed, the Rear Cross Chain transports the potatoes to the left or right side of the windrower, where they are discharged into the furrow(s) of adjacent undug rows.

INFO

Legend for Figure 1: (1) Digger Nose, (2) Primary Chain, (3) Secondary Chain, (4) Vine Chain, (5) Rear Cross Chain, (6) Discharge.

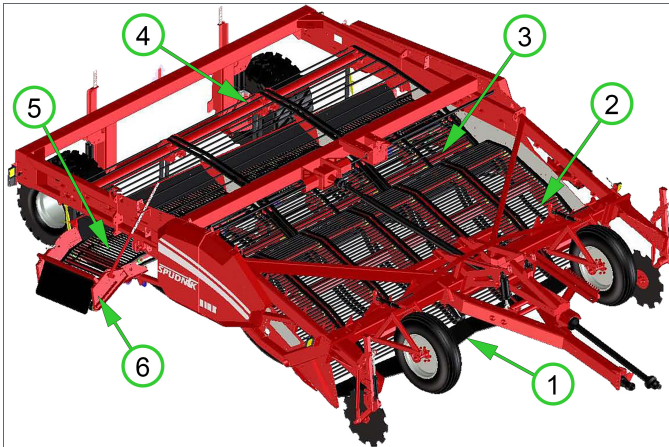

Figure 1

STEP 2: Make Connections

Objective: Introduce the operator to the mechanical, hydraulic, and electrical connections of the Spudnik 6160^{S4} Windrower.

Connecting the Windrower to the Tractor

IMPORTANT

Before connecting the windrower to the tractor, verify the tractor meets the requirements to tow and operate the windrower.

Back the tractor into position in front of the windrower. Stop short of the implement drawbar, but close enough to make required hydraulic and electrical connections.

Mechanical Connections

Before making the mechanical connections, a hydraulic and an electrical connection are required in order to raise/lower the windrower drawbar. See **[Important]** at the beginning of [Hydraulic Connections](#) and **[Important]** at the beginning of [Electrical Connections](#).

Connect the drawbar hydraulic hoses to a Selective Control Valve (SCV) port on the tractor. (See [Figure 2](#) and [Figure 5](#))

SINGLE BAND	- PRESSURE LINE	
DOUBLE BAND	- RETURN LINE	
RED	- VALVE BANK	10 GPM
BLACK	- DRAWBAR	20 GPM
BLUE	- REAR CROSS	
GREEN	- SHAKERS	
YELLOW	- WHEEL ASSIST	20 GPM
ORANGE	- CASE DRAIN	

300637

Figure 2

Connect the (1) Tractor ISOBUS cable connector to the Implement Bus Break-away Connector (IBBC) port on the tractor. Confirm that the (2) *CAN Disconnect B* and (3) *CAN Disconnect A* connectors are securely connected. (See [Figure 3](#) and [Figure 5](#))

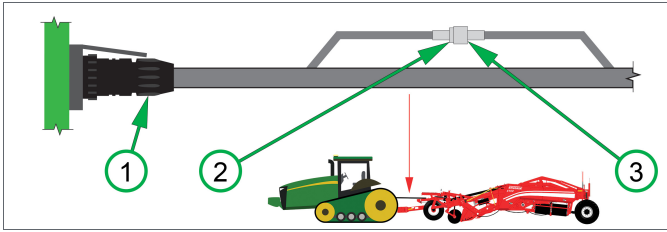
**Figure 3**

Start the tractor and engage the SCV port with the drawbar hydraulic hoses connected.

Using the Digger Switch, (1) raise or (2) lower the windrower drawbar to vertically align the windrower hitch with the tractor drawbar. (See [Figure 4](#))

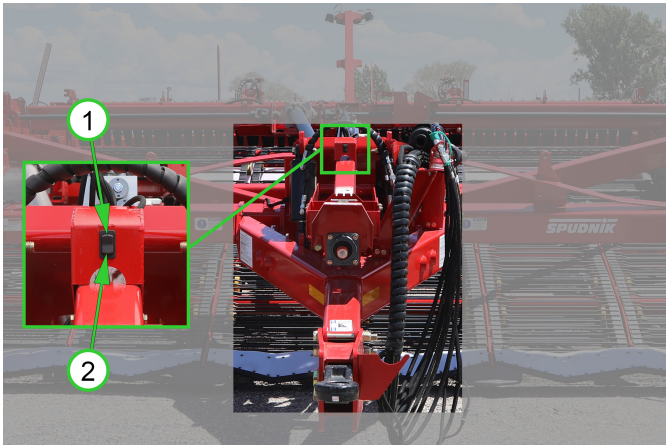
**Figure 4**

Finish positioning the tractor and connect to the windrower drawbar.

IMPORTANT

For windrowers equipped with the pull ring drawbar hitch option, the tractor three-point lift arms limit the safe turning angle. Even completely raised, the lift arms may contact the windrower PTO shaft. Remove the lift arms to prevent damage to the windrower PTO shaft.

Turn off the tractor and connect the windrower PTO to the tractor.

Hydraulic Connections

IMPORTANT Be sure hydraulic system (machine and tractor) is depressurized prior to connecting hydraulic hoses to the tractor.

Connect any remaining hydraulic hoses from the windrower to SCV ports on the tractor.

The rear of a typical tractor provides the identified ports: (1) SCV, (2) Power Beyond, (3) Case Drain, (4) Tractor Lights, (5) IBBC, (6) Load Sense. Available ports, their arrangement, and their color designations vary by tractor manufacturer and model. (See [Figure 5](#))

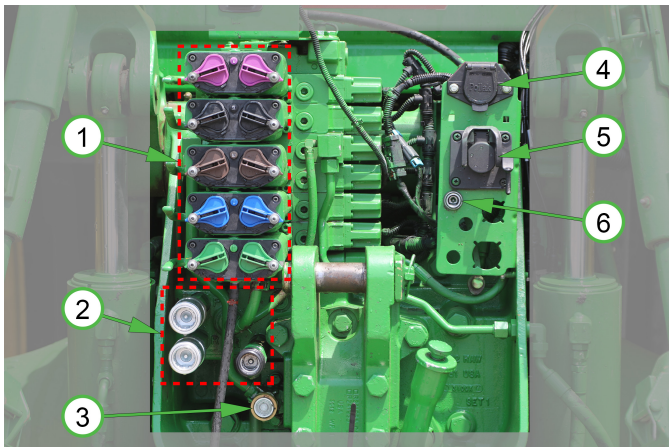

Figure 5

Electrical Connections

IMPORTANT To prevent damage to electrical components, deenergize affected circuit by turning off the tractor and tractor key before connecting/disconnecting electrical cables.

Connect the (2) Tractor Lighting connector on the windrower (1) Tractor Lights cable into the Tractor Lights port on the back of the tractor. (See [Figure 6](#))

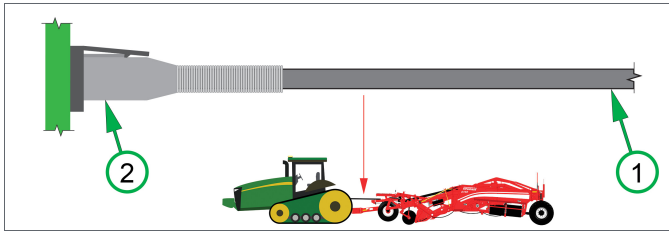

Figure 6

With the CX3 controller mounted in the tractor, configure the ISOBUS connectivity as appropriate for the towing tractor and the desired functionality. (See [\[Info\]](#), and [Figure 7](#) through [Figure 12](#))

INFO

Legend for Figure 7 through Figure 12: (1) Tractor ISOBUS, (2) CAN Disconnect B, (3) CAN Disconnect A, (4) Connector C1, (5) Connector C2, (6) Connector C3, (7) Connector C4, (8) CAN In [Pin], (9) CAN Out [Socket], (10) CAN Bus Cable PN 440035, (11) CAN Bus Cable PN 440036, (12) CAN Bus Cable PN 440401, (13) Spudnik "Y" Adapter PN 440021, (14) Joystick CAN Connector [Pin], (15) In-cab ISOBUS Connector 9-Pin, (16) In-cab ISOBUS Harness [Inline], (17) CAN Bus Cable PN 440109, (18) CAN Bus Terminator PN B94.01736.

In-Cab ISOBUS connection (with CX3). (See [\[Info\]](#), Figure 7, and Figure 8)

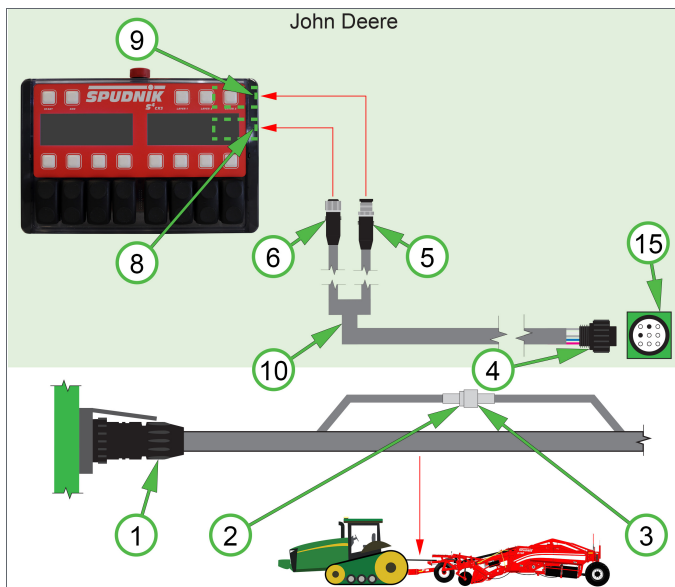

Figure 7

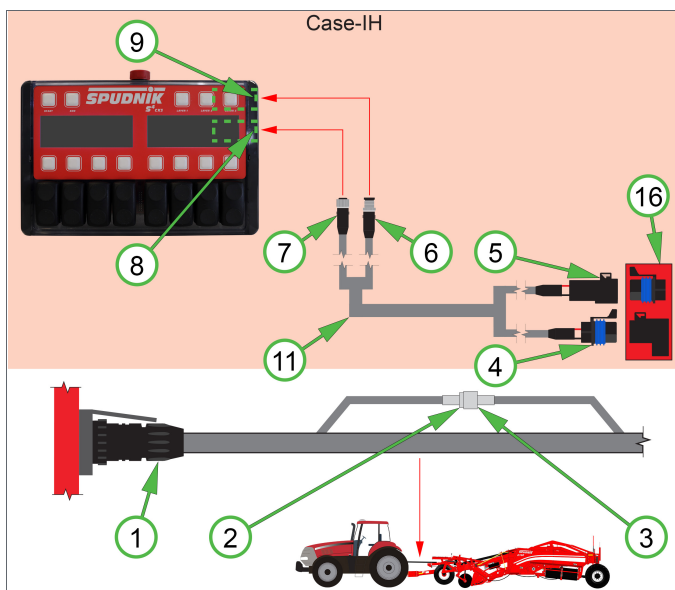

Figure 8

In-Cab ISOBUS connection (with CX3 and Joystick). (See [\[Info\]](#), Figure 9, and Figure 10)

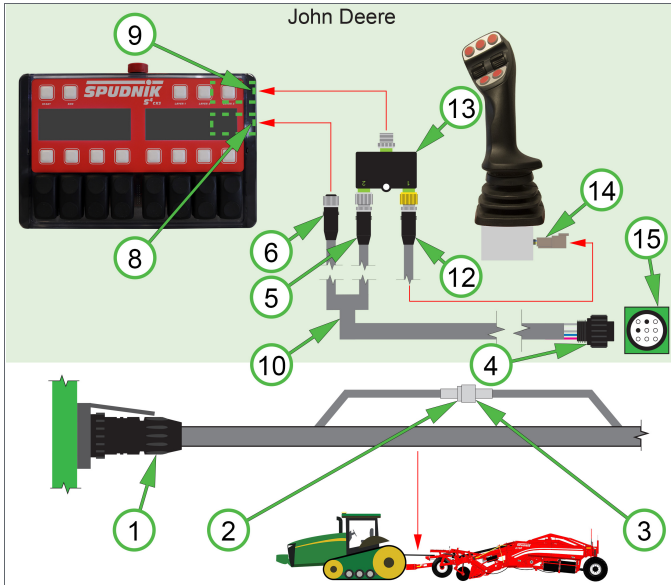

Figure 9

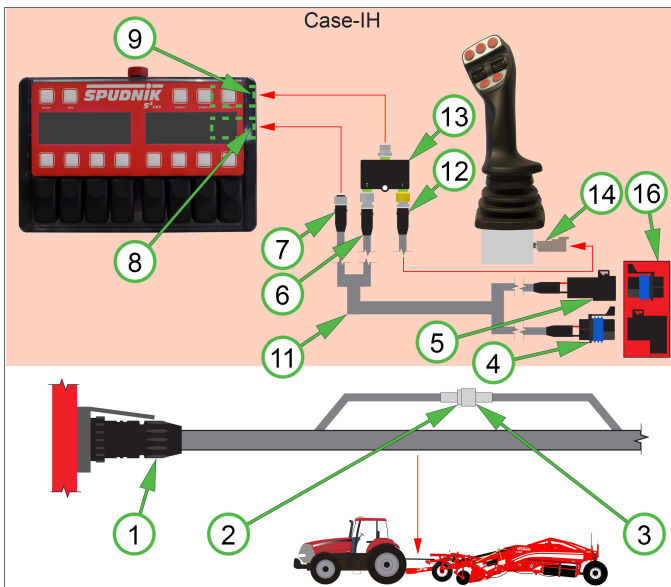

Figure 10

Back-window ISOBUS connection (with CX3). (See [\[Info\]](#) and [Figure 11](#))

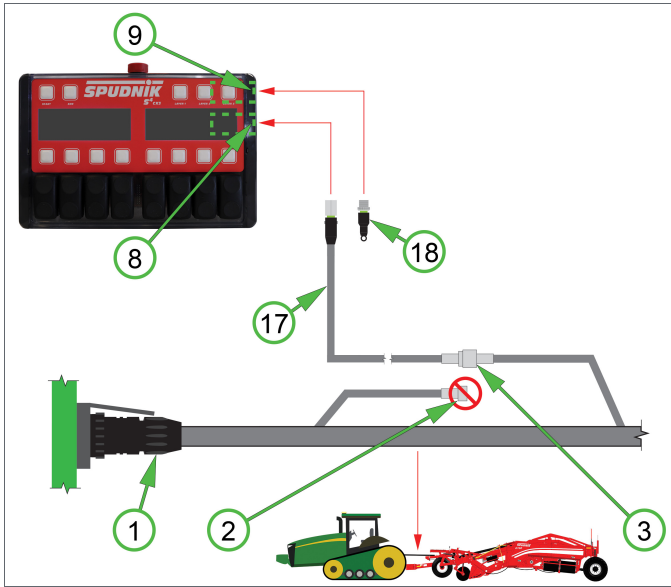

Figure 11

Back-window ISOBUS connection (with CX3 & Joystick). (See [Info](#) and Figure 12)

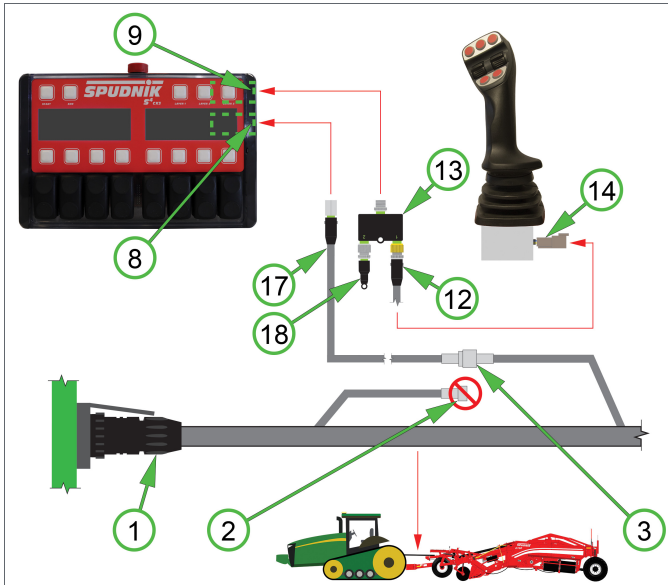

Figure 12

STEP 3: Perform Pre-Run Setup

Objective: Guide the operator in setting basic Spudnik 6160^{S4} Windrower functions for successful harvesting operation.

Before initial operation, review and confirm completion of necessary pre-run setup and programming. All pre-run setup and programming is accessed via the *MENU* screen on the CX3 controller. (see [Introduction to the CX3 Controller](#)) From the Home screen, press soft key 1 (*PRESS FOR MENU*) to access the *MENU* screen. (See [Figure 13](#))

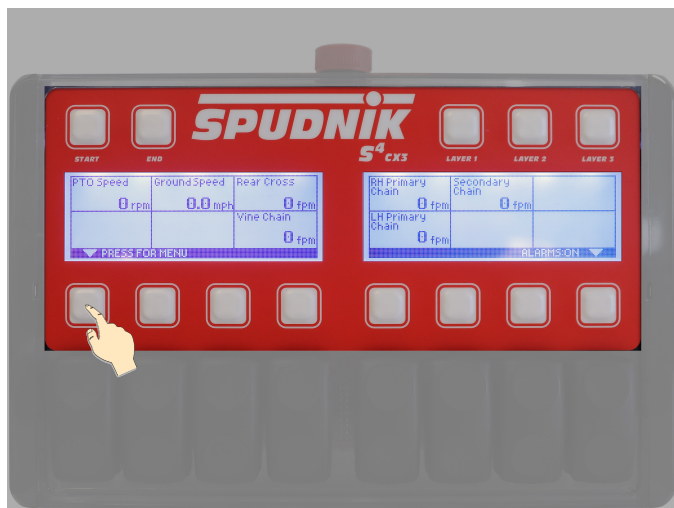

Figure 13

Upon completion of programming, press soft key 4 (*EXIT*) to exit the *MENU* screen and return to the Home screen. (See [Figure 14](#))

Button Assignments

Default control mapping is loaded at the factory. The operator may change the button mapping to meet personal preferences. To remap the buttons:

1. On the *MENU* screen, use soft key 1 (*UP*) and/or soft key 2 (*DOWN*) to move the cursor to highlight *2-Button Assignments*. Press soft key 3 (*ENTER*) to access the *FUNCTION POSITIONING* screen. (See [Figure 14](#))

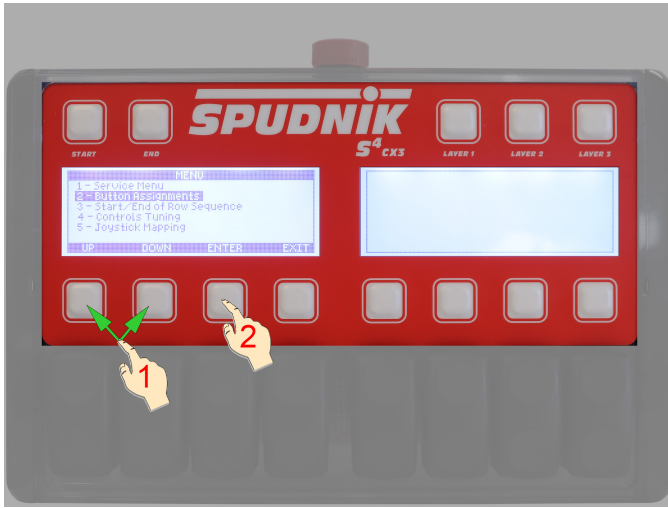

Figure 14

2. The *FUNCTION POSITIONING* screen opens in the left display and populates with the first entry. Use soft key 1 (*PREV*) or soft key 2 (*NEXT*), to scroll through the functions. (See [Figure 15](#))

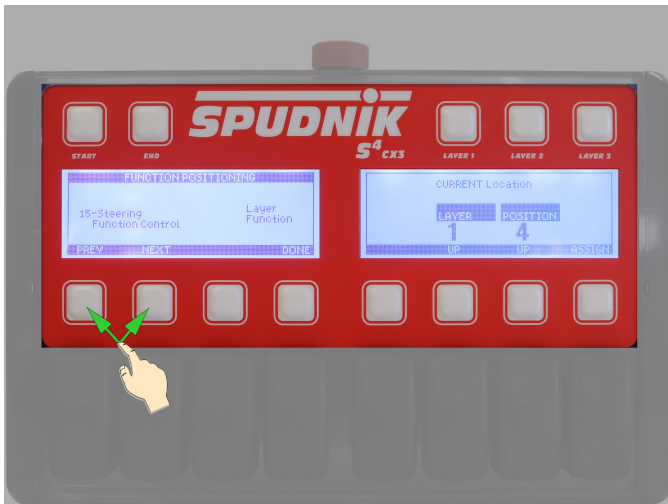

Figure 15

The right display shows the function location in the *LAYER* and *POSITION* fields. The *LAYER* variable corresponds to the display screen associated with the *LAYER 1*, *LAYER 2*, or *LAYER 3* soft keys, and with Home, which displays when no layer soft key is activated.

The *POSITION* variable corresponds with position locations on the Home or layer screens. The (1) Home screen is divided into 12 position locations. The (2) Layer 1, (3) Layer 2, and (4) Layer 3 screens are each divided into 8 position locations. (See [Figure 16](#))

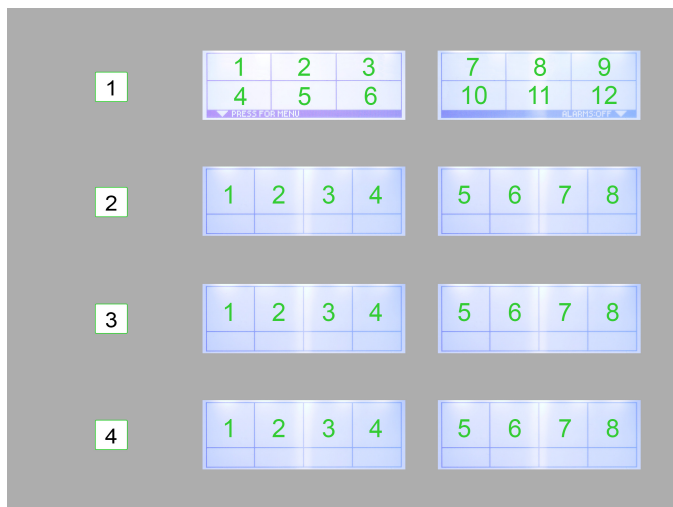

Figure 16

IMPORTANT

The *FUNCTION POSITIONING* screen displays different functions depending on the options installed on the windrower. When scrolling through the list, the screen displays only the functions associated with the options configured on the windrower. If incorrect functions appear, or if physically installed functions are missing, the configuration may be set up incorrectly. Contact your local Spudnik representative for service.

IMPORTANT If a function location has not been assigned, the *LAYER* and/or *POSITION* fields will display *unassigned*. If the function location has been previously assigned, the *LAYER* and *POSITION* fields will display the currently assigned location. To remove a function that was programmed in error, or is no longer used, set both the *LAYER* and *POSITION* variables to *unassigned*.

IMPORTANT For the Button Assignments programming example, the function *15-Steering* is selected. All instructions assume this selection. To program other functions, substitute the variables for the chosen function in place of the *15-Steering* variables listed.

- Using the data displayed on the CX3 *FUNCTION POSITIONING* screen, enter the *LAYER* and *POSITION* location for function *15-Steering*.
- Press soft key 6 (*UP*) to scroll to *LAYER* variable 1. (See [Figure 17](#))

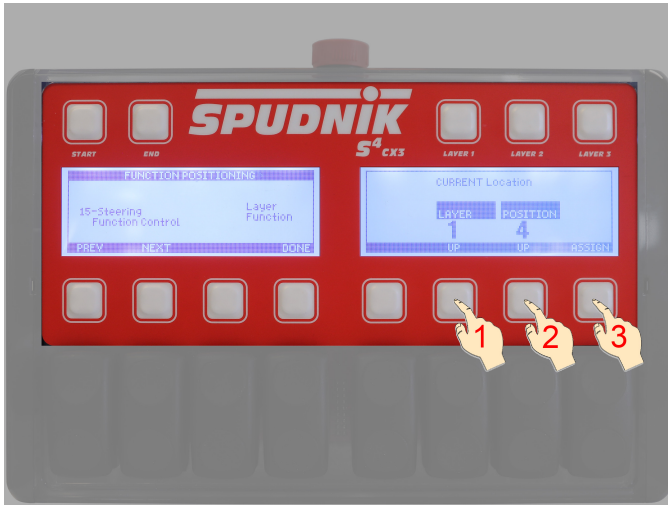

Figure 17

5. Press soft key 7 (*UP*) to scroll to *POSITION* variable 4.
6. To save the location changes, press soft key 8 (*ASSIGN*). Alternatively, if you do not wish to save the location change, go to step 7 without pressing the *ASSIGN* key.
7. Press soft key 2 (*NEXT*) to scroll to the next function. (See [Figure 18](#))

The *FUNCTION POSITIONING* screen populates with the next available function. If reverse scrolling will reach a function with fewer keystrokes than forward scrolling, press soft key 1 (*PREV*) to scroll to the previous function.

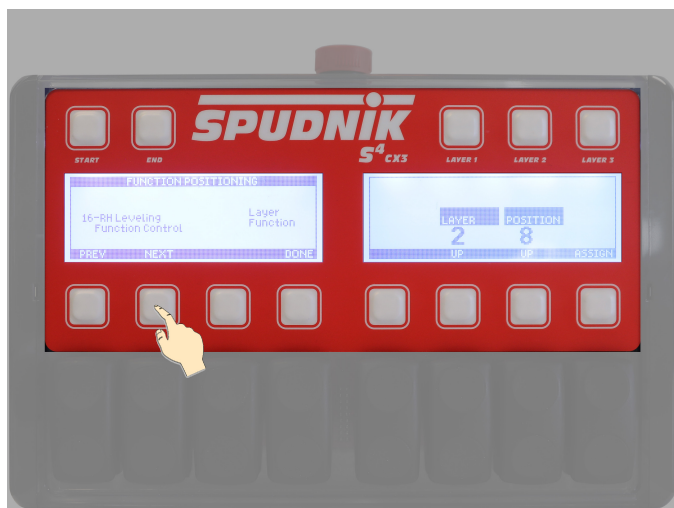

Figure 18

8. Repeat the process defined in steps 4-7 to navigate through the remaining functions. Assign functions to user-determined positions on the CX3.
9. Press soft key 4 (*DONE*) to exit the *FUNCTION POSITIONING* screen and return to the *MENU* screen.

Joystick Mapping

The Joystick provides an alternative to the CX3 for controlling many of the win-drawer functions. The Joystick controls include the Joystick axis, rocker switch position, and momentary button depression. Depending on its mapping, the Joystick will control up to 16 unique functions. (See [\[Info\]](#) and [Figure 19](#))

INFO

Legend for Figure 19: (1) Top Center Button, (2) Top Right Button, (3) Right Rocker, (4) Bottom Right Button, (5) Bottom Left Button, (6) Left Rocker, (7) Top Left Button, (8) Front Rocker, (9) Front Button, (10) Y Axis Forward, (11) X Axis Right, (12) Y Axis Backward, (13) X Axis Left.

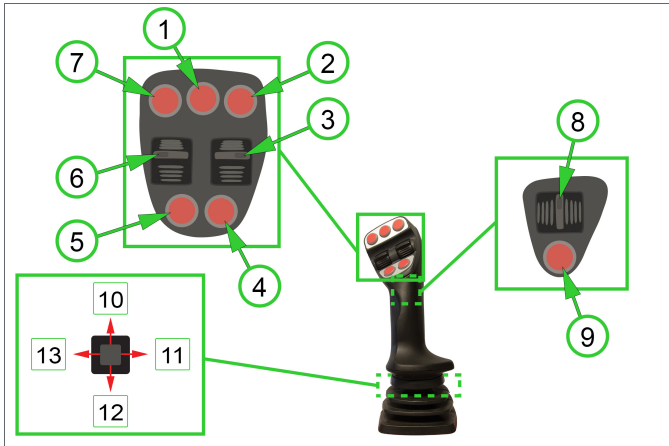

Figure 19

Default joystick mapping is performed at the factory. If the windrower options do not utilize all the default Joystick mapping, or if the operator desires to change any of the default controls or functions, Joystick mapping is accessed through the CX3 controller. To remap the Joystick:

1. On the *MENU* screen, use soft keys 1 (*UP*) and/or 2 (*DOWN*) to move the cursor to highlight *5-Joystick Mapping*. Press soft key 3 (*ENTER*) to access the *Joystick Control* screen. (See [Figure 14](#))
2. Joystick controls can be remapped using the Joystick or the CX3 (e.g., if the Joystick is temporarily unavailable). To remap using the Joystick, activate the Joystick axis position, momentary button, or rocker switch to be remapped. The name of the active Joystick control displays on the left screen. The *Current Value* and (1) *New Value* fields display on the right screen. (See [Figure 20](#))

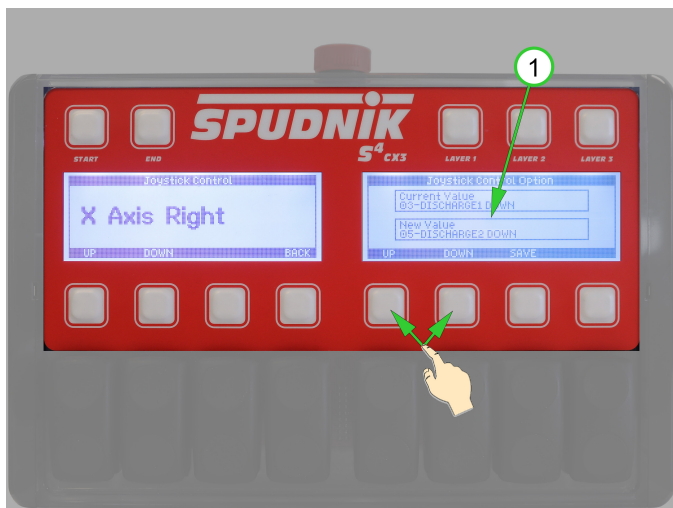

Figure 20

3. Using the soft keys 5 (*UP*) and/or 6 (*DOWN*), scroll up/down to populate the *New Value* field with the desired Joystick function. Press soft key 7 (*SAVE*) to save the selected Joystick function. The *Current Value* field updates to the value contained in the *New Value* field. Repeat for each axis position, momentary button, or rocker switch to be remapped.
4. To remap using the CX3, use the soft keys 1 (*UP*) and/or 2 (*DOWN*) to scroll up/down to populate the *Joystick Control* field on the left screen with the desired Joystick control. Then, using the soft keys 5 (*UP*) and/or 6 (*DOWN*), scroll up/down to populate the *New Value* field on the right screen with the desired Joystick function. Press soft key 7 (*SAVE*) to save the selected Joystick function. The *Current Value* field updates to the value contained in the *New Value* field.
5. Press soft key 4 (*BACK*) to exit the Joystick mapping screens and return to the *MENU* screen.

Start/End of Row Setup

Start of Row and End of Row programming is operating condition specific and should be reviewed and revised before beginning operation.

1. On the *MENU* screen, use soft keys 1 (*UP*) and/or 2 (*DOWN*) to move the cursor to highlight *3-Start/End of Row Sequence*. Press soft key 3 (*ENTER*) to access the *ROW SEQUENCE MENU* screen. (See [Figure 14](#))

- The *ROW SEQUENCE MENU* screen opens with the *1-Start of Row Sequence* option selected. Press soft key 3 (*ENTER*) to access the *Start of Row* screen. (See [Figure 21](#))

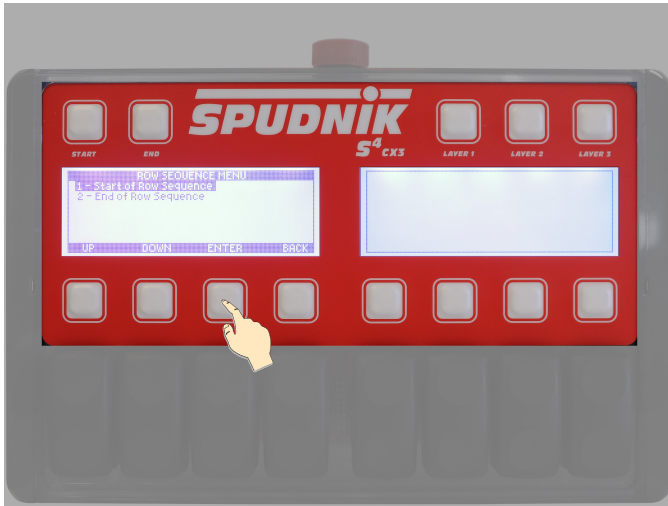
**Figure 21**

- The *Start of Row* screen opens with the first function displayed on the left screen. The associated (1) *Turn on Time (sec)* and (2) *Duration (sec)* fields are displayed on the right screen. (See [Figure 22](#))

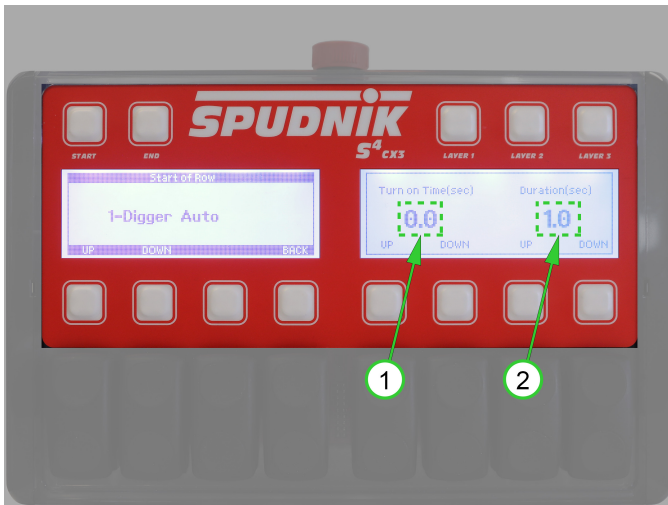
**Figure 22**

- There are nine start of row functions in the Start/End Of Row (SEOR) sequence. Scroll through the start of row functions to display and/or edit the associated *Turn on Time (sec)* and *Duration (sec)* values. Press soft keys 1 (*UP*) and/or 2 (*DOWN*) to scroll through the start of row functions. For an example of how the nine start of row functions could be programmed, see [Figure 23](#). In the figure, (1) indicates when the *START* key is activated.

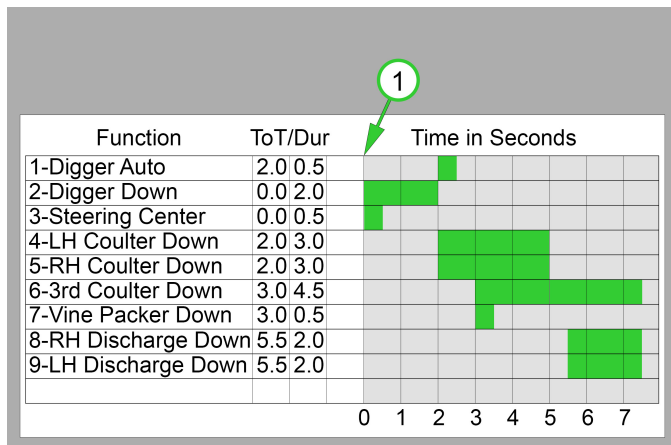

Figure 23

- Each *Turn on Time (sec)* value is calculated from the time the *START* key is activated. This allows functions to activate in any sequence, regardless of the list order. To edit the *Turn on Time (sec)* value, press soft key 5 (*UP*) to incrementally increase the start time. Press soft key 6 (*DOWN*) to incrementally decrease the start time.
- The *Duration (sec)* values are unique for each function. This enables each function to operate for its individually specified time. Some AUTO functions require a duration greater than 0.1 seconds to engage. To ensure engagement of AUTO functions, use a duration of 0.5 seconds or greater. To edit the *Duration (sec)* value, press soft key 7 (*UP*) to incrementally increase the duration time. Press soft key 8 (*DOWN*) to incrementally decrease the duration time.
- Repeat from step 1 for the end of row setup. For the ten end of row functions in the SEOR sequence, see [Figure 24](#). In the figure, (1) indicates when the *END* key is activated.

IMPORTANT

Functions 9 and 10 are not applicable to the 6160^{S4} Windrower. Leave turn-on time and duration set to 0.0 seconds.

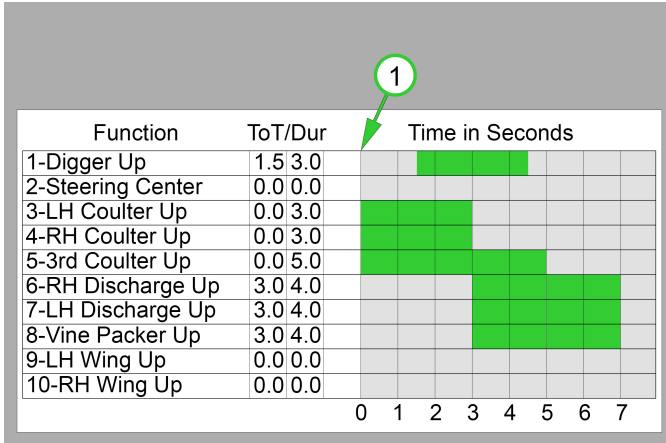

Figure 24

STEP 4: Understand Controls

Objective: Familiarize the operator with Spudnik 6160^{S4} Windrower controls.

Operating Controls

The operator controls the windrower by means of controls located in the tractor's operator station. This Quick Start Guide assumes the operator is trained on and familiar with the operation of the tractor controls.

The tractor controls required to operate the windrower include SCVs and the PTO.

The tractor mounted controls required to operate the windrower include the CX3 controller and the optional Joystick.

Introduction to the CX3 Controller

The CX3 controller is the primary control interface for the windrower's hydraulic systems which are not controlled directly by the tractor's SCVs. The CX3 comes from the factory with a default configuration which can be

remapped according to the operator's preferences. The CX3 displays information via two LCD screens. It accepts operator input via soft keys and rocker switches.

The CX3 is powered on/off using the tractor ignition key. At the completion of the power-on boot sequence, the CX3 displays the Home screens. The Home screens display navigation prompts such as (1) Soft Key Indicator, (2) Navigation Action, and (3) Function Action, as well as ground speed and the (4) speed of various windrower systems. (See [Figure 25](#))

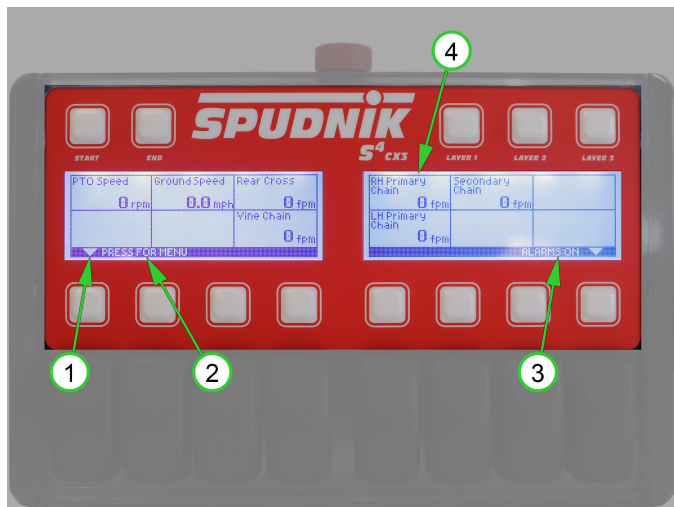

Figure 25

The CX3 has 13 physical soft keys arranged in two rows. The (1) top row are fixed function keys. The (2) bottom row are programmable function keys. Operation of the programmable keys changes depending on the function associated with the softkey. The function changes with the selected layer. (See [Figure 26](#))

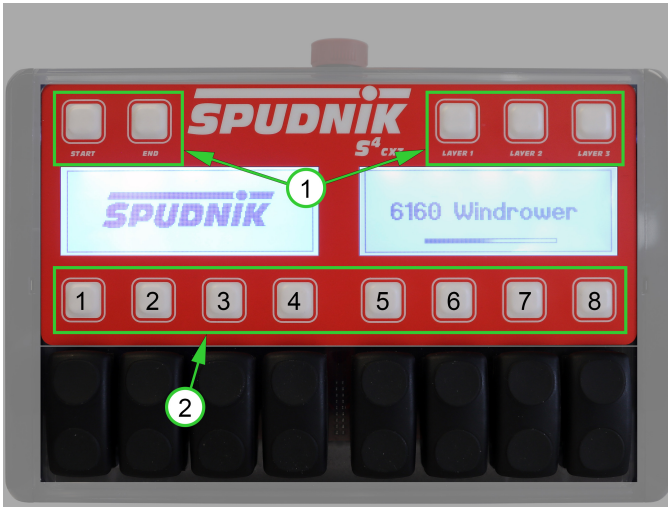

Figure 26

The CX3 has eight rocker switches arrayed below the bottom row of soft keys. The rocker switches are numbered in the same sequence as the soft keys. Like the soft keys, the function changes according to the selected layer. Each function is arranged in a (1) control column. Each control column displays the function name and the action associated with the rocker switch. For example, (2) up and (3) down, right/left, more/less, etc. (See [Figure 27](#))

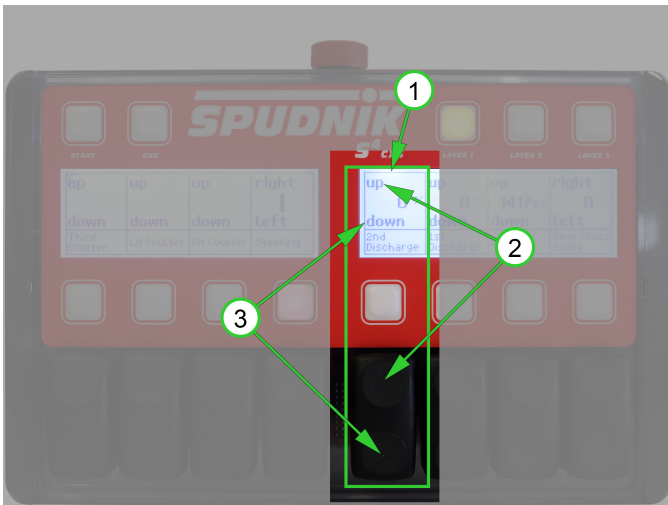

Figure 27

The layer soft keys access and display three different layers of control functions. The (1) layer soft key illuminates when activated. When active, up to eight control functions display in (2) columns which contain a (3) function name at the bottom and (4) function action at the top. Press individual layer keys to toggle between active and inactive. (See [Figure 28](#))

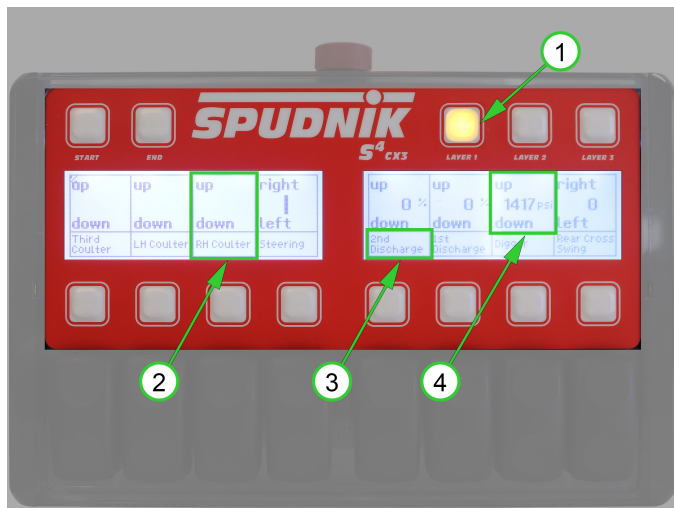

Figure 28

! DANGER!

The Machine Stop does not stop all functions. Those functions driven by the PTO, such as the Primary Chain, and those driven directly by an SCV, such as the main hydraulic reverse drive, will continue to run. Do not use the Machine Stop as an E-Stop.

! CAUTION!

The Machine Stop is not an E-Stop. Control circuits remain energized even when the Machine Stop button is engaged. Treat all electrical circuits as energized until proven otherwise.

The Machine Stop is a two-position push-button switch. In, the Machine Stop is (1) engaged. Out, the Machine Stop is (2) disengaged. When engaged, the S4 control board receives a signal to turn off all outputs, terminating machine operation. Even though machine operation stops, the control circuits are still energized, and the machine will resume operation when the Machine Stop button is reset. Press the Machine Stop button to shut down the machine and lock

out all S4 control board controlled operations. Rotate the Machine Stop button clockwise to release the button lock and enable machine operation. (See [Figure 29](#))

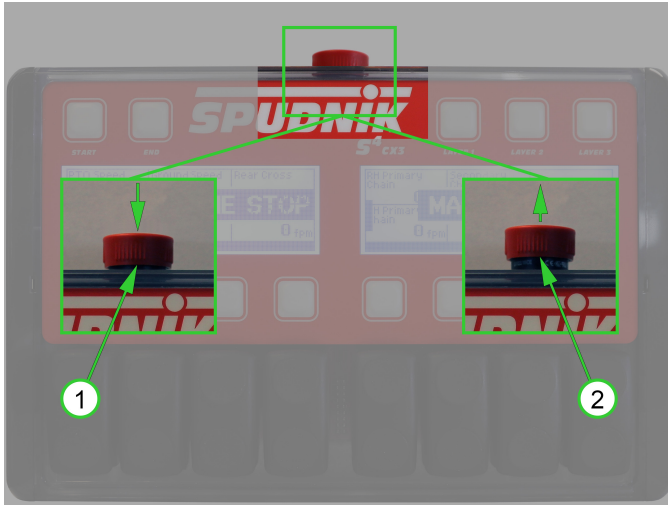

Figure 29

STEP 5: Operate the Windrower

Objective: Enable the operator to successfully harvest potatoes using the Spudnik 6160^{S4} Windrower.

IMPORTANT

Instructions assume default button assignments for the CX3 Controller. For CX3 layout, see [Introduction to the CX3 Controller](#). To remap the buttons, see [Button Assignments](#).

Custom Settings

Use this section to record settings for the 6160^{S4} Windrower.

Tractor Make & Model: _____

CX3 ID/Name: _____

Joystick ID/Name: _____

ISOBUS Connection: _____

Ground Speed: _____

Hydraulic Settings:

Band Color	Function	SCV Port	Flow Rate	Detent Mode
Red				
Black				
Blue				
Green				
Yellow				

Creating a Setpoint

IMPORTANT The Creating a Setpoint instructions use the *Steering* and auto return to center functions as examples. To program setpoints for other functions, substitute the chosen functions (e.g., discharge angle) in place of *Steering* and auto return to center.

1. Press the *LAYER 1* rocker switch 4 (*Steering*) up/down to position the windrower's steerable wheels so they are parallel, and the windrower tracks straight behind the tractor. (See [Figure 30](#))
2. Confirm the (1) *LAYER 1* soft key 4 (*Steering*) is not illuminated, indicating the auto return to center function is turned off.
3. Press and hold *LAYER 1* soft key 4 (*Steering*) for approximately three seconds. A beep confirms the setpoint has been set, and the (2) turn indicator displays the steering position as centered.
4. Test the setpoint by steering left or right, then engaging the auto return to center function by momentarily pressing *LAYER 1* soft key 4 so it illuminates. Confirm the windrower tracks straight behind the tractor.

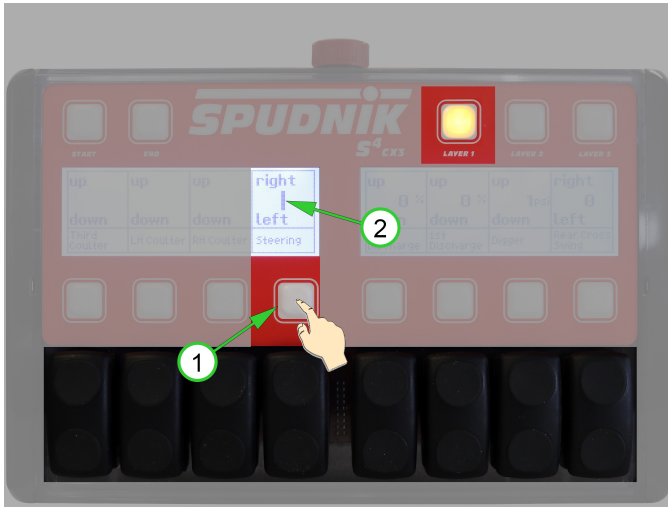

Figure 30

Ridge Relief

Ridge Relief constantly monitors and maintains the up pressure on the Digger Nose. Ridge Relief functions to prevent overloading the digger when the windrower passes over the crest of a hill, or when it enters a soft spot in the field. Conversely, Ridge Relief functions to maintain adequate loading when the windrower passes through the depression between hills. Based on the operator setpoint, the Ridge Relief shifts the weight from the windrower to the tractor drawbar, maintaining a constant implement drawbar loading regardless of the digger depth or contour of the ground.

Ridge Relief is engaged/disengaged by using *LAYER 1* rocker switch 7 (*Digger*) to lower/raise the digger nose. (See [Digger Control](#))

When programmed in the SEOR sequence, Ridge Relief activates/deactivates by pressing the *START/END* keys. (See [Start/End of Row Setup](#))

In addition, Ridge Relief/Digger control can be manually engaged/disengaged by pressing *LAYER 1* soft key 7 (*Digger*) which toggles Ridge Relief (2) on and (1) off. (See [Figure 31](#))

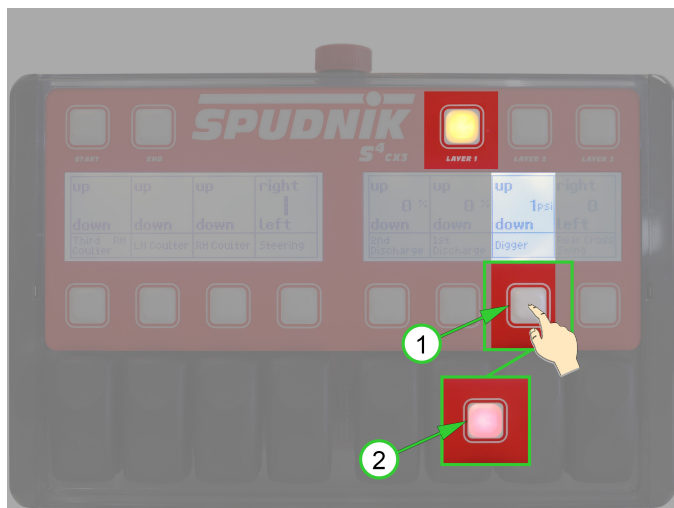
**Figure 31**

Setting Ridge Relief Pressure

⚠ WARNING! The tractor must be running and the hydraulic system must be pressurized while setting the Ridge Relief pressure. Observe hydraulic safety precautions. Pressurized hydraulic oil presents a penetration and infection risk, resulting in severe injury and possible death.

IMPORTANT To prevent possible equipment damage, raise the Depth Wheels or TerraFloat drums clear of the ground before adjusting the Ridge Relief pressure. Wait to set the depth control until the Ridge Relief pressure is set.

The Ridge Relief/Digger pressure is set by adjusting the pressure reducing relieving valve, TS1, using the (1) adjusting screw. (See [Figure 32](#))



Figure 32

IMPORTANT The Ridge Relief operating pressure range is from 900 to 1,200 psi for Depth Wheels and 1,100 to 1,400 psi for TerraFloat. Do not exceed the top pressure setting. Excessive pressure could result in equipment damage.

1. While monitoring the Digger pressure display on the CX3, adjust the hex socket head screw to set the desired operating pressure.
2. Increasing the operating pressure increases the weight transferred to the drawbar, which decreases the weight applied to the Depth Wheels.
3. Rotate the screw clockwise to increase pressure.
4. Decreasing the operating pressure decreases the weight transferred to the drawbar, which increases the weight applied to the Depth Wheels.
5. Rotate the screw counterclockwise to decrease pressure.
6. Test the Ridge Relief operation to confirm the pressure setting delivers the desired operational performance.

Digger Control

Digger control engages up/down movement of the digger nose.

IMPORTANT When equipped with the TerraFloat with drive option, entering/exiting digger nose Ridge Relief turns the TerraFloat drive on/off.

Press LAYER 1 rocker switch 7 (*Digger*) down to lower the digger nose. The (1) soft key illuminates and the digger nose powers down for as long as the rocker switch is held. Upon releasing LAYER 1 rocker switch 7 (*Digger*), the digger nose enters Ridge Relief. (See [Figure 33](#))

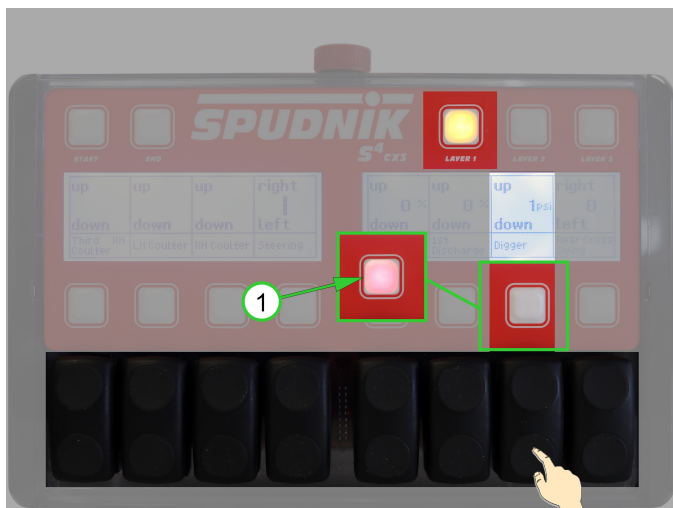

Figure 33

Press LAYER 1 rocker switch 7 (*Digger*) up to raise the digger nose. The (1) soft key light turns off and the digger nose powers up for as long as the rocker switch is held. Upon releasing LAYER 1 rocker switch 7 (*Digger*), the digger nose exits Ridge Relief. (See [Figure 34](#))

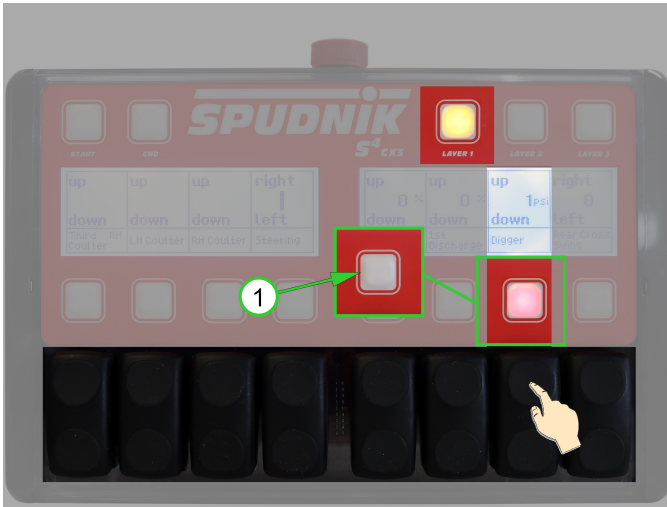

Figure 34

Depth Wheel Depth Control

Depth control holds the Digger Blade at a specific height, providing terrain following for consistent inflow. Depending on the options installed, the Depth Wheels are either manually or hydraulically controlled.

For manual control. Use the (1) LH/RH ratchet jack to raise/lower the Depth Wheel which raises/lowers the digger nose. Count the threads or measure the ratchet jack spread to set to the LH/RH Depth Wheels to the same position. (See Figure 35)

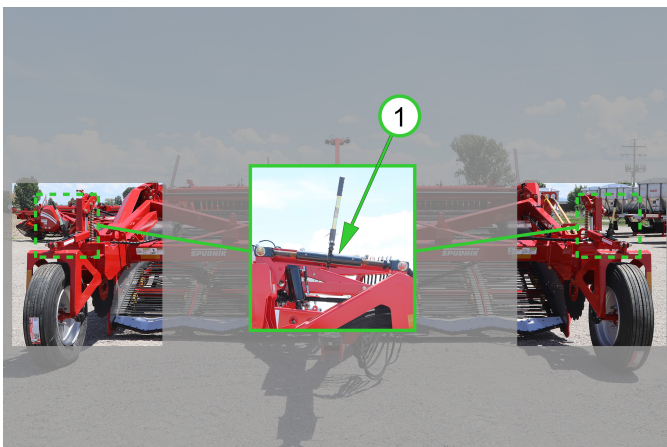

Figure 35

Lower the Depth Wheel to raise the digger nose.

Raise the Depth Wheel to lower the digger nose.

For hydraulic control. Press LAYER 2 rocker switch 1 and/or 2 (*RH Depth Wheel/LH Depth Wheel*) down to lower the Depth Wheel, raising the digger nose. The Depth Wheel powers down for as long as the rocker switch is held. (See [Figure 36](#))



Figure 36

Press LAYER 2 rocker switch 1 and/or 2 (*RH Depth Wheel/LH Depth Wheel*) up to raise the Depth Wheel, lowering the digger nose. The Depth Wheel powers up for as long as the rocker switch is held. (See [Figure 37](#))



Figure 37

Primary Chain Drive

The Primary Chain is driven by the tractor PTO.

Engage the tractor PTO to start the Primary Chain.

Change the PTO speed to create a corresponding speed change in the Primary Chain.

Disengage the tractor PTO to stop the Primary Chain.

Primary Chain Hydraulic Reverse Option

The Primary Chain Hydraulic Reverse Kit enables the operator to stop the forward PTO drive while hydraulically driving the Primary Chain in reverse to clear a bind.

IMPORTANT

drive.

To prevent belt damage, stop the PTO before engaging the hydraulic reverse

1. Disengage the tractor PTO.
2. Engage the Primary Chain reverse drive by reversing the flow on the SCV controlling the hydraulic shakers. Reversing the hydraulic flow extends the actuating cylinder, removing tension from the forward

drive belt, while tensioning the reverse drive belt. The hydraulic motor drives the reverse drive belt, reversing the Primary Chain drive.

3. When the Primary Chain bind clears, engage the SCV controlling the hydraulic shakers in the normal flow direction. The actuating cylinder on the Hydraulic Reverse Kit retracts, disengaging the reverse drive belt and tensioning the forward drive belt.

Alarm Display

The S4 control board monitors the system for operational failures. (For a list of alarms ranked by priority, see [Figure 38](#).)

Priority	Operational Alarm (Alarm Type)
1	Digger Nose Overpressure (Visible & audible alarm) <i>Confirm the return line is connected to the tractor. Check for cylinder damage.</i>
2	Hydraulic flow insufficient to sustain active Wheel Assist drive at the prevailing ground speed. (Audible alarm)
2	PTO above 300 rpm and Primary Chain drops below 22 fpm. (Audible alarm)
2	PTO above 300 rpm and Secondary Chain drops below 22 fpm. (Audible alarm)
2	PTO above 300 rpm and Vine Chain drops below 22 fpm. (Audible alarm)
2	PTO above 300 rpm and Rear Cross Chain drops below 22 fpm. (Audible alarm)
Normal Operation	No Alarms Activated

Figure 38

When an operational failure is detected, the applicable alarm alerts. Visible alarms display on the (1) left screen. Audible alarms produce a warning tone but do not display visibly. The alarm resets once the operational failure is resolved. (See [Figure 39](#))

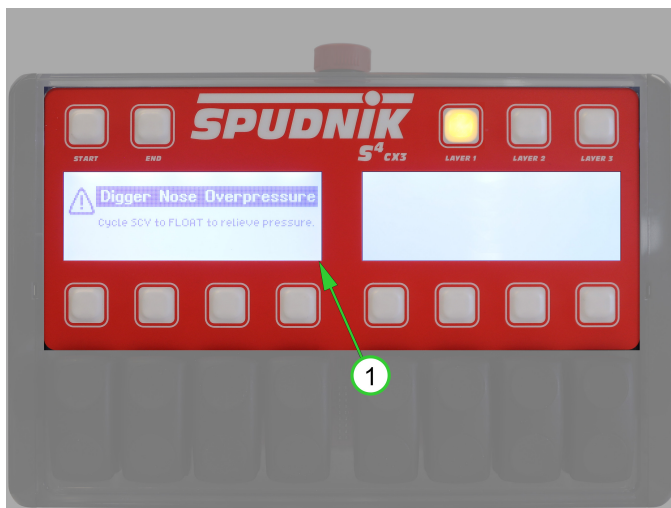

Figure 39

For additional Spudnik 6160^{s4} Windrower documentation, scan the QR code.



584 West 100 North
P.O. Box 1045
Blackfoot, ID 83221
+1 (208) 785-0480
spudnik@spudnik.com
www.spudnik.com