

 **HORSCH**

Leeb LT

INTELLIGENT SPRAYING TECHNOLOGY





Leeb LT

Engineering for professionals with perfect application accuracy and high ease of use

- Less drift and high operational speeds due to active boom control system and low target area spacing
- High operational speeds due to hydropneumatic boom damping and reduction of the target height down to 30 cm.

- Complete circulation in stainless steel circulation tubes to the nozzle
- High continuous clearance of up to 85 cm and a maximum steering angle of 28°



Depending on the requirements and applications the HORSCH Leeb LT is to cover, it can be adapted very individually. Due to the three different tank capacities of 4 000 l, 5 000 l or 6 000 l, the Leeb LT provides sufficient capacity for large fields or high application rates. Due to the very deep tank and as it is tapered towards the top, the centre of gravity is transferred far towards the bottom and there still is a clearance of up to 85 cm. This is mainly due to the innovative way of the production of the tank. The tank is rotated in one piece and there are no seams or joints in the tank - the inside of the tank completely smooth. The smooth inside walls of the tank considerably help the cleaning as the cleaning fluid drains off in an optimum way. Due to the continuous inside cleaning system, only a push of the button is required. Depending on the equipment, the farmer can even choose between several washing programs. Individual components, such as the boom or the filters, can be cleaned separately. This makes sense especially in the evening or when the spraying process is interrupted.

The farmer also has a lot of options to choose from with regard to track width and tyres. With regard to the track widths, he can choose between 1.80 m and 2.25 m, whereas special track widths are possible for special requirements. To protect the soil, the tyre also plays a very important role. The larger the diameter of the tyre, the larger the contact area. This actively prevents excessive compaction. In combination with the IF and VF tyres, the air pressure can even be lowered. We particularly benefit from this advantage for plant protection sprayers with the automatic tyre pressure control system ATP Control (Adapted Tyre Pressure Control). Together with the steering angle of max. 28°, the LT is not only a very flexible crop care sprayer, but also very sophisticated in every detail.



High clearance and smooth underbody



Maximum crop protection and exact following in the tracks

CONDITIONS OF USE



- The steering angle of up to 28° ensures a small turning radius and optimum manoeuvrability. The automatic locking and centring of the steering axle as of 16 km/h guarantees a safe and comfortable road transport - not least due to the spring-loaded axle arm with level compensation.
- The continuous inside cleaning system guarantees a reliable cleaning when changing chemicals.
- Due to the nozzle layout of 25 cm combined with the active boom control system BoomControl, drift can be prevented and the application quality is increased.

- High filling rates due to a low-wear 600 l/min rotary pump with variable drive for an optimum control of the application rate.
- Due to numerous equipment options like Adapted Tyre Pressure Control, booms up to a working width of 45 m and tank capacities of up to 6 000 l, the Leeb LT can be adapted to almost all customer requirements.



Theodor Leeb

With regard to the development of our Leeb LT, the focus is on utmost precision combined with optimum efficiency.

Basic

Water system Basic

In the equipment line Basic, the HORSCH Leeb LT and the HORSCH Leeb GS are equipped with a drive shaft driven piston diaphragm pump with an output of 400 l/min (filling connection 3" from 5-way valve, 3" lines on the suction side) and Load Sensing connections. Suction and pressure

- Piston diaphragm pump with an output of 400 l/min with PTO-shaft drive
- 3" filling connection and 3" lines on the suction side
- Pressure sensor for monitoring the spraying pressure and pressure regulator for adjusting the flow rate
- Suction and pressure side can be operated manually
- Electronic level indicator on the mixture tank



Water system Basic

side are operated via manual multi-way valves. The spraying pressure is monitored with a pressure sensor and a pressure regulator adjusts the flow rate. The tank is equipped with an electronic level indicator.

CCS

ContinuousCleaningSystem

The CCS water system guarantees a continuous inside cleaning of tank, lines and boom. The additional CCS piston diaphragm pump for cleaning pumps clean water into the spray lines, the spraying pump removes the residual mixture from nozzles and the spray lines instead of diluting it. This allows the system to be cleaned quickly, thoroughly and

- Safe and quick cleaning by displacing the mixture from the lines
- Quick cleaning process of the sprayer without having to get off
- Complete control of the cleaning process in the cabin
- Electronic level indicator at the mixture tank with automatic switch-off
- Fast, thorough, and water consumption-optimized cleaning

with an optimised water consumption – without having to get off the machine directly from the cabin – and the sprayer is completely cleaned when leaving the field. On the machine, a powerful rotary pump with Load Sensing is used with manual operation for the suction and pressure side.



ContinuousCleaningSystem

CCS Pro

ContinuousCleaningSystem Pro



ContinuousCleaningSystem Pro (CCS Pro)

In addition to the characteristics of the CCS system, for the CCS Pro version several cleaning programs can be started easily and comfortably at the push of a button in the cabin

1. Complete cleaning: rinses injector line - via the filter to the boom - completely with fresh water and then continues with the continuous inside cleaning (CCS) for mixture tank and boom.
2. Dilution: dilute the spraying mixture in the desired ratio with just a few simple steps
3. Intensive washing program: recommended for an extra thorough cleaning, e.g. when changing between crops.
4. Boom cleaning: automatic rinsing of the boom, e.g. if the work is interrupted for several hours
5. Background cleaning: intelligent, continuous inside cleaning that cleans the inside wall of the tank with fresh water while spraying. This prevents deposits on the tank wall.

The pressure control in the system is carried out via the pump speed. The pump only conveys the amount of liquid that is required for spraying plus the defined quantity for the agitator and thus used especially energy-saving. Fresh water as well as mixture tank are equipped with an electric level indicator for automatic washing programs and an automatic switchoff.

- Continuous inside cleaning with several cleaning and rinsing programs, can be operated comfortably in the cabin
- Pressure sensors for pump, agitator, inside cleaning and boom, suction and pressure side electrically controlled
- Operation with a large external terminal with all important induction functions
- Quick cleaning process of the sprayer without having to get off
- Relaxed filling process due to the standard automatic two filling limits
- Automatic filling level dependent agitator performance and switch-off



External control terminal CCS Pro

Water cycle - Basic - Leeb LT

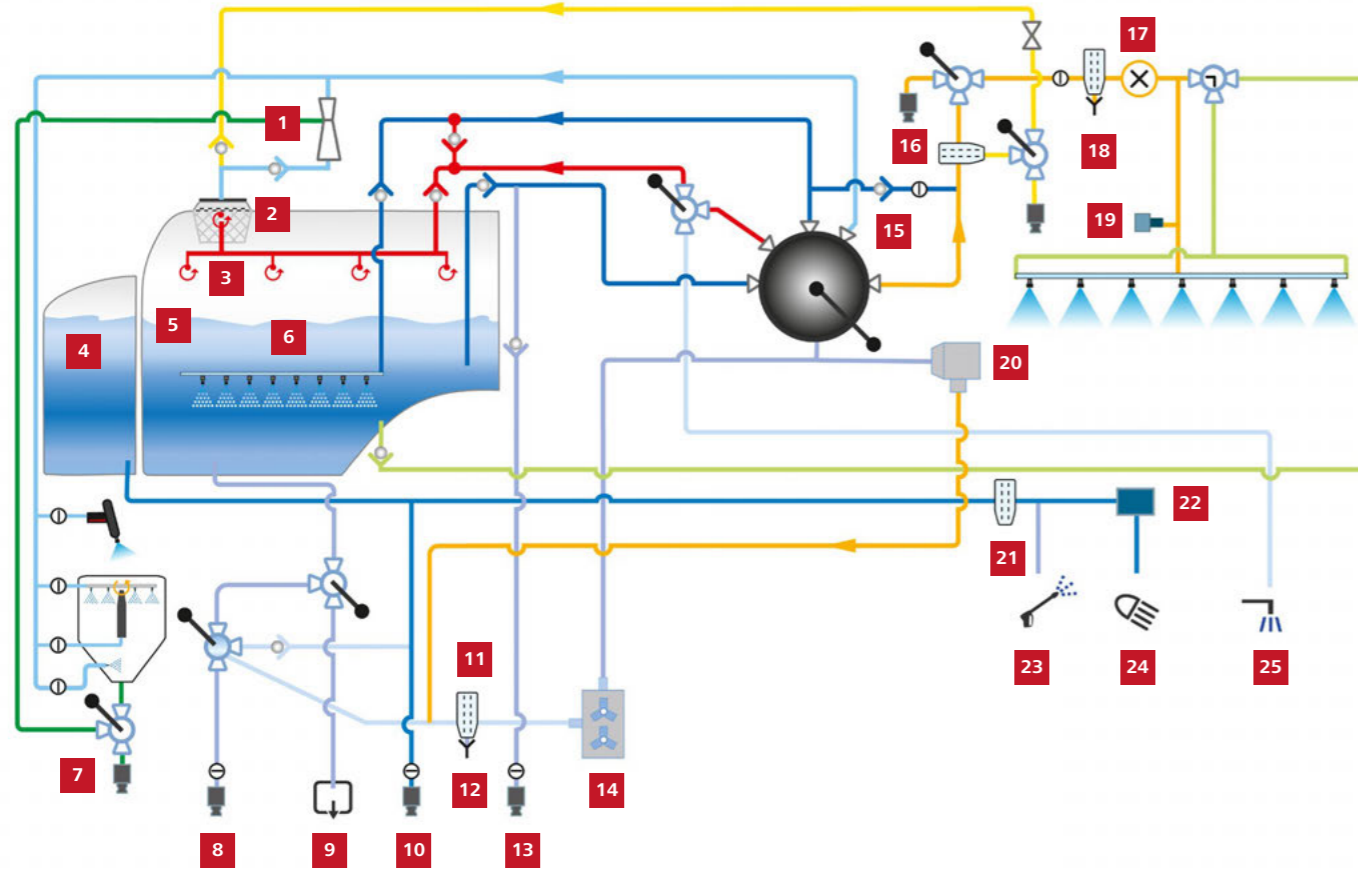

- | | | |
|--------------------------------|---|-------------------------------------|
| 1 Injector | 10 Filling fresh water | 19 Pressure sensor |
| 2 Dome sieve | 11 Suction filter | 20 Pressure controller Basic |
| 3 Inside cleaning | 12 Discharge valve | 21 Filter |
| 4 Fresh water tank | 13 Direct filling | 22 Electric pump |
| 5 Spraying mixture tank | 14 Piston diaphragm pump 6 cylinders | 23 High-pressure cleaner |
| 6 Agitator | 15 Bypass agitator | 24 NightLight cleaning |
| 7 Filling sluice | 16 1. pressure filter | 25 Outside cleaning |
| 8 Suction filter | 17 Flow meter | |
| 9 Residual discharge | 18 2. pressure filter with discharge valve | |

Water cycle - CCS - Leeb LT

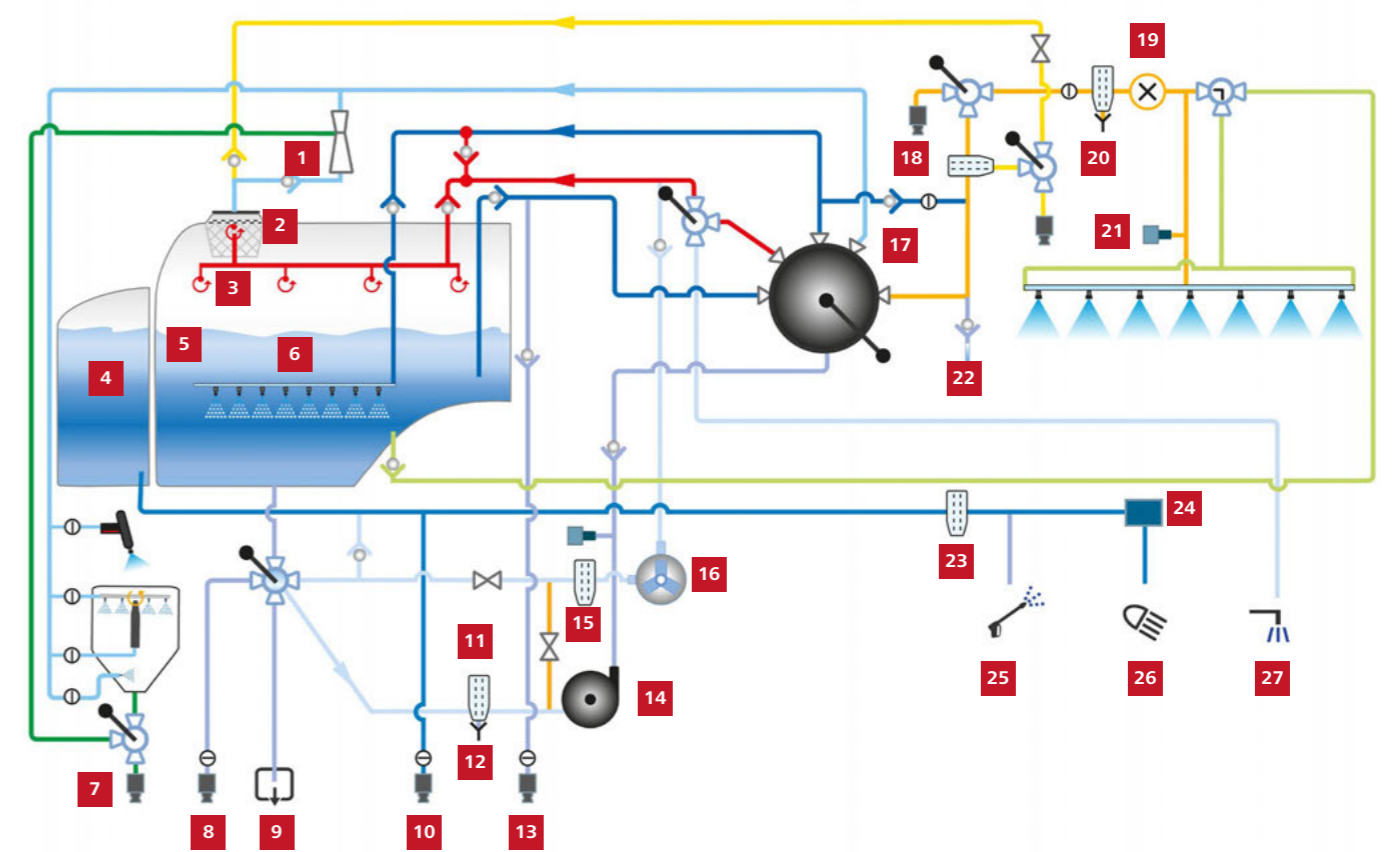

- | | | |
|--------------------------------|---------------------------------|---|
| 1 Injector | 10 Filling fresh water | 19 Flow meter |
| 2 Dome sieve | 11 Suction filter | 20 2. pressure filter with discharge valve |
| 3 Inside cleaning | 12 Discharge valve | 21 Pressure sensor |
| 4 Fresh water tank | 13 Direct filling | 22 Exhaust function for residual quantity |
| 5 Spraying mixture tank | 14 Rotary pump | 23 Filter |
| 6 Agitator | 15 Fresh water filter | 24 Electric pump |
| 7 Filling sluice | 16 Piston diaphragm pump | 25 High-pressure cleaner |
| 8 Suction filter | 17 Bypass agitator | 26 NightLight cleaning |
| 9 Residual discharge | 18 1. pressure filter | 27 Outside cleaning |

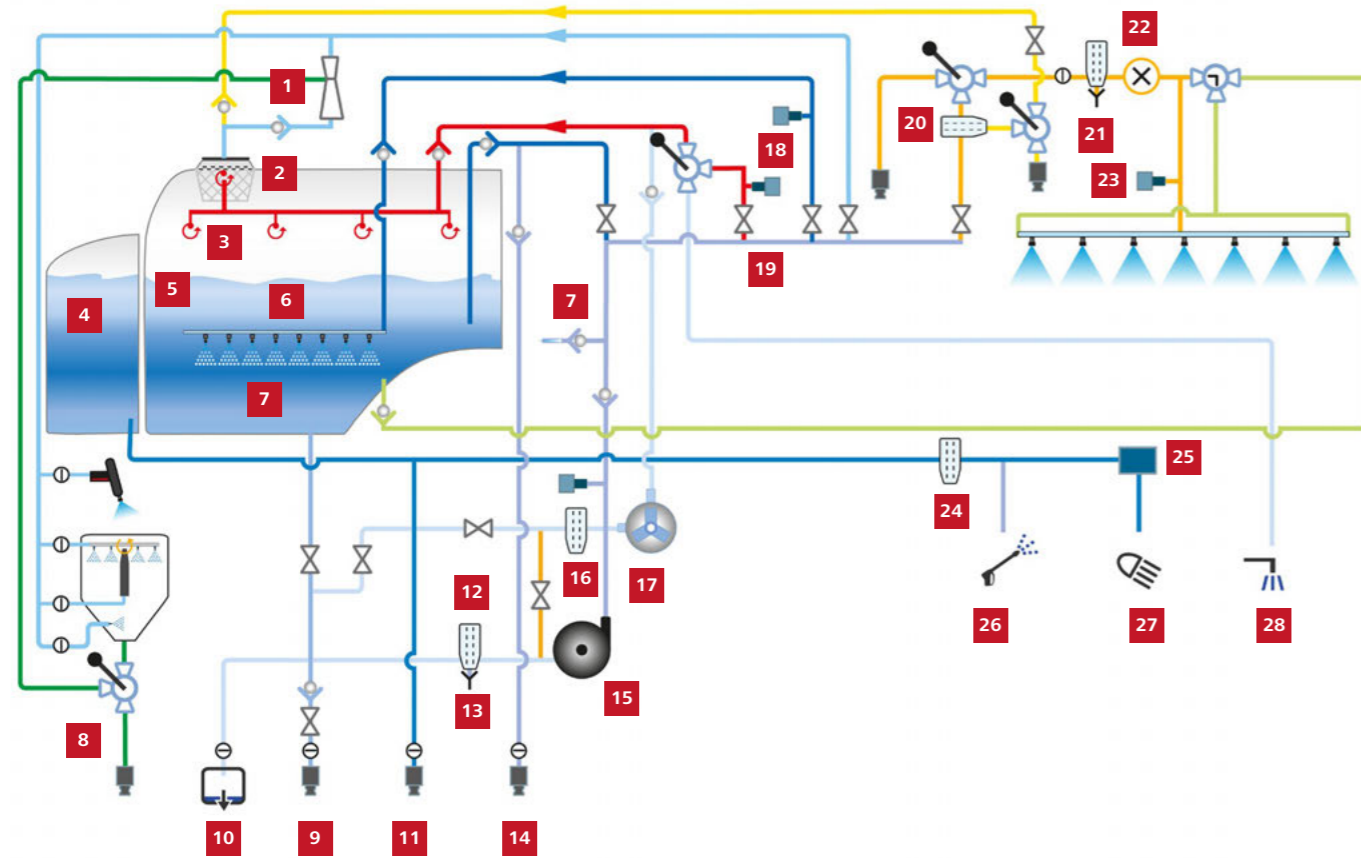

- | | | |
|---|---------------------------------|---|
| 1 Injector | 11 Filling fresh water | 21 2. pressure filter with discharge valve |
| 2 Dome sieve | 12 Suction filter | 22 Flow meter |
| 3 Inside cleaning | 13 Discharge valve | 23 Pressure sensor |
| 4 Fresh water tank | 14 Direct filling | 24 Filter |
| 5 Spraying mixture tank | 15 Rotary pump | 25 Electric pump |
| 6 Agitator | 16 Fresh water filter | 26 High-pressure cleaner |
| 7 Exhaust function for residual quantity | 17 Piston diaphragm pump | 27 NightLight cleaning |
| 8 Filling sluice | 18 Pressure sensors | 28 Outside cleaning |
| 9 Suction filling | 19 Electric switch unit | |
| 10 Residual discharge | 20 1. pressure filter | |

Distribution system and induction hopper

No hose is the best hose

The sophisticated distribution system ensures an optimum supply of boom, intensive agitator, inside tank cleaning and induction hopper. Only one hose and one return flow hose are required for the circulation of the spraying mixture across the entire boom width, thus minimising deposits and facilitating cleaning.

The swivelling induction hopper with a gas pressure absorber and a durable stainless steel labelling is equipped with an efficient injector ring. Upper and lower rinsing nozzles create a whirl-like circulation for quickly flushing-in liquids and are also suitable for granulate. Moreover, the induction hopper is equipped with an additional canister cleaning nozzle as well as a symbol bar with coloured control levers.

As an option, the stainless steel induction hopper pot is available with a capacity of 52 l and the additional shock nozzle.



52 l stainless steel induction hopper incl. additional shock nozzle

- Permanent circulation of the active ingredient solution
- Large tube and line cross sections for optimum circulation, no deposits and blockages
- Permanent spraying fluid at the nozzle, exact switching on and off
- Powerful induction hopper with convincing functions
- Safe cleaning: displacement of the mixture with fresh water

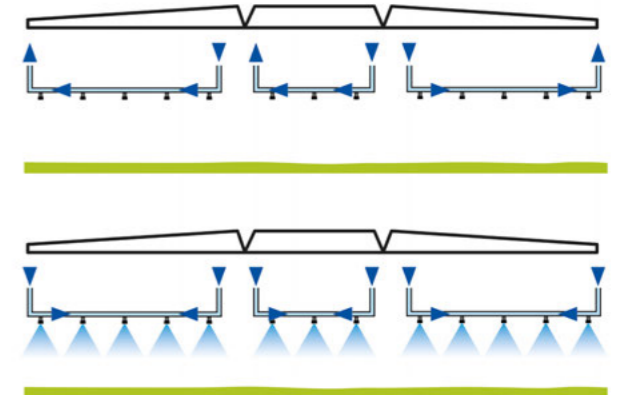

When the pump is running, a mixture circulates continuously in the boom (top) so that it is immediately available at the nozzle when spraying (bottom).

Boom options

Precise technology – sophisticated to the last detail

With regard to the boom, we rely on the well-proven system consisting of parallelogram suspension and the well-proven boom control system BoomControl that guarantees an extremely smooth boom position even in very uneven terrain and with high operational speeds. The patented suspension with active control of the middle section prevents immersion during cornering and on the headlands. Basic boom options are available in widths ranging from 18 to 45 m. Different folding options allow for an individual adaption of the working width. The sophisticated boom folding allows for an optimum and compact transport position: the boom does not come up to the tractor cabin. This prevents damage to the cabin roof and prevents spraying mixture from splashing on the rear area of the tractor.



- Parallelogram suspension with BoomControl for stable boom position in all conditions
- Basic boom options in working widths ranging from 18 to 45 m
- Transport width 2.55 m, transport height 3.40 to 3.55 m (depending on tyres and track)

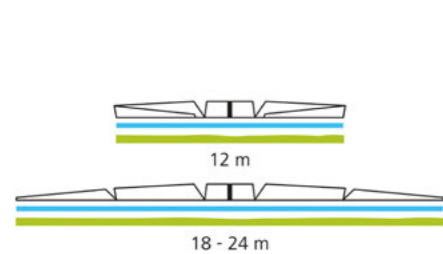

BoomControl – 5-part with reduced working width 12 m

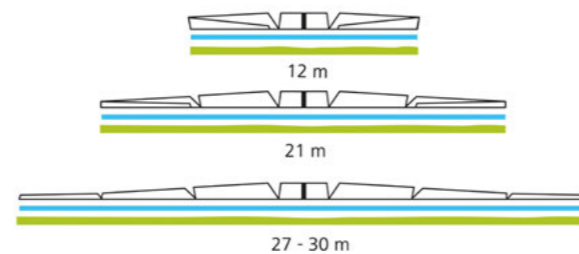

BoomControl - 7-part with reduced working width 12 m and 21 m

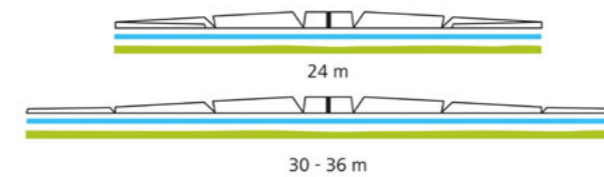

BoomControl - 7-part with reduced working width 24 m

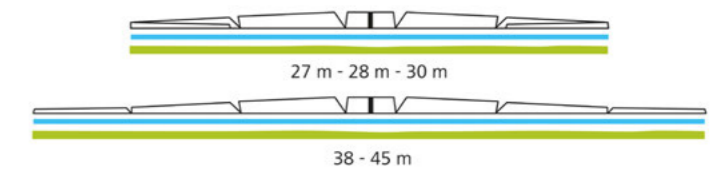

BoomControl – 7-part with reduced working width 27, 28 and 30 m

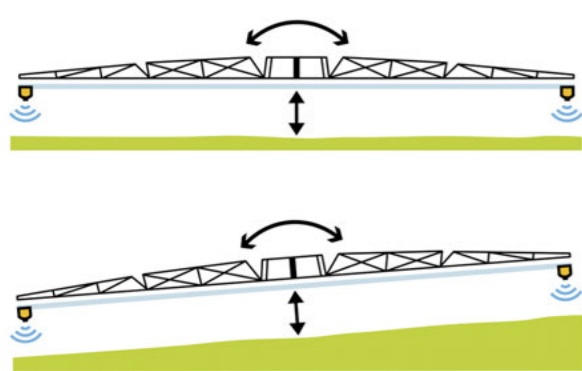

BoomControl – active adaption of the boom to the terrain due to two sensors

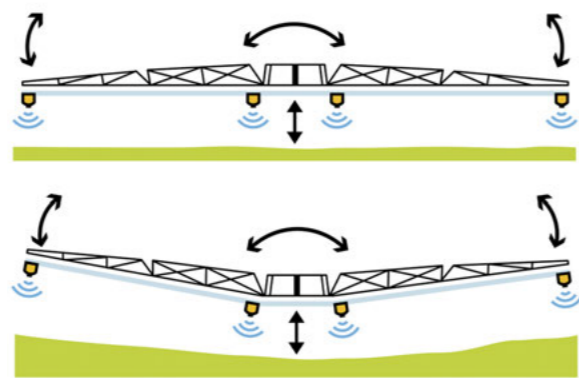

BoomControl Pro – active adaption of the boom to the terrain by means of four sensors

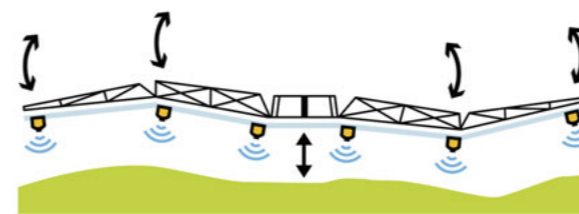

BoomControl Pro Plus

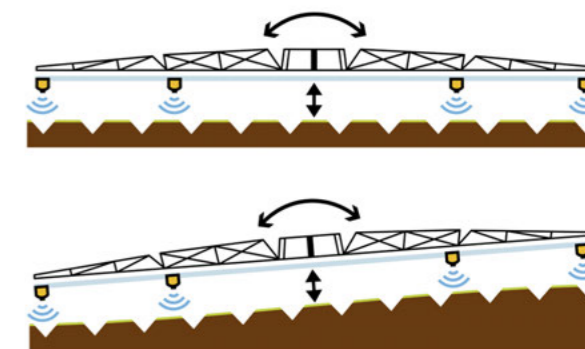

BoomControl/BoomControl Pro extension – extension of the field of vision is ideal for ridge and row crops

BoomControl

Active boom control system
BoomControl

- Maintenance of the exact, lowest possible working height due to active boom control system
- Boom control system with a target area spacing of less than 40 cm ensures minimal drift
- Active adaption of the boom to the terrain by means of two sensors

BoomControl Pro

Active boom control system
BoomControl Pro

- Independent angling of the boom arms and rotation of the middle section to adapt to the terrain
- Active adjustment of the boom to the terrain with 4 sensors
- Maintenance of the exact, lowest possible working height due to automatic boom control system
- Boom control system with a target area spacing of less than 40 cm ensures minimal drift
- Boom is completely decoupled from the vehicle

BoomControl Pro Plus

Active boom control system
BoomControl Pro Plus

- Independent angling of the boom arms and rotation of the middle section to adapt to the terrain
- Angling (lifting and lowering) of the two outside wings
- Active adjustment of the boom to the terrain by via sensors
- Maintenance of the exact, lowest possible working height due to automatic boom control system
- Boom control system with a target area spacing of less than 40 cm ensures minimal drift

Extension

BoomControl/BoomControl Pro

- Active adaption of the boom to the terrain by means of two additional sensors
- To extend the field of vision
- Ideal for ridge and row crops or for reduced working widths

PrecisionSpray

Pulse width modulation – state-of-the-art application technology



PrecisionSpray is a pulse nozzle system that triggers the nozzles in a pulsating way at a frequency of 20 Hertz. This allows for adjusting the application steplessly via the Duty Cycle – with constant pressure and drop size at variable speed and while maintaining the spraying characteristics. This allows for using larger nozzles which are less susceptible to clogging, and the number of necessary nozzle sizes are minimised. For optimal longitudinal and transverse distri-

bution, the nozzles are switched alternately. The system is fully integrated into ISOBUS and the HORSCH sprayer software: with curve compensation and the use of application maps, over- and underdosage can be avoided actively. Active resistance management and even populations with minimal mixture consumption make the nozzle a tool for Precision Farming.

- Infinitely variable adjustment of the flow rate at constant pressure and droplet size
- Constant drop spectrum when using a nozzle
- Fewer different nozzle sizes required
- Adjustment of the application rate without altering spraying characteristics
- Curve compensation and VariableRate per section
- Generally larger nozzle bodies that are less prone to clogging

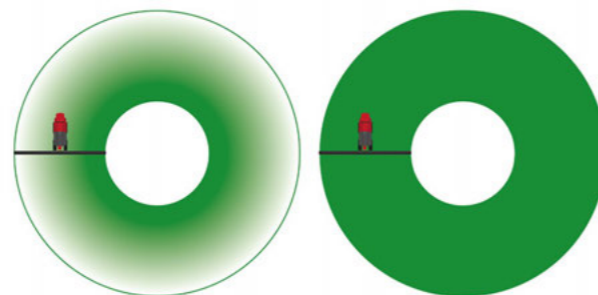

Avoid over and under applying due to curve compensation

Pneumatic nozzle and section control

Performance due to diversity

Due to the pneumatic nozzle control and the pneumatic section control, it is possible to precisely switch off nozzles and sections with compressed air. Nozzle spacings of 25 cm and 50 cm are available.

This allows for individual and intelligent application technologies to achieve optimal penetration and wetting of the crop. Variable nozzle body combinations (pneumatically switchable) can also be used. All nozzles are controlled

individually and are pneumatically combined in sections. This also facilitates maintenance and the easy detection and repair of errors and blockings at the nozzles. As standard, all nozzle body configurations are equipped with nozzle holders for edge nozzles. Comprehensive tests in our wind tunnel show considerable advantages with regard to the drift behaviour depending on the target height.

- Individually controlled nozzles, combined pneumatically in sections
- 6 to 42 possible sections (standard sections or individual configuration options)
- Excellent penetration and wetting of the population
- Optimum target area spacing with a nozzle spacing of 25 cm
- Allows for individual and intelligent application technologies

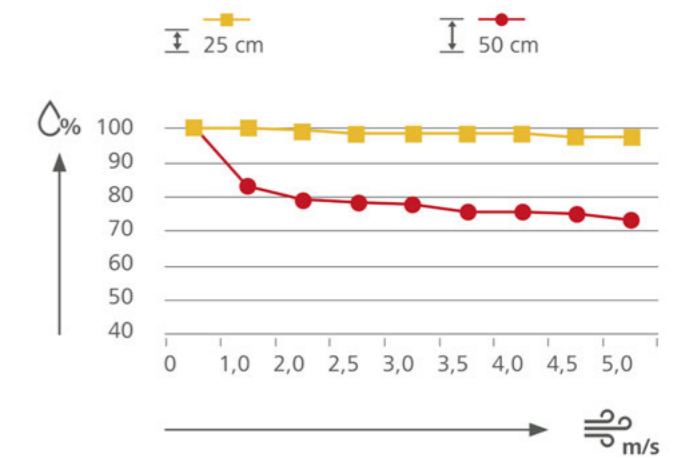

Drift comparison: wetting (in %) depending on the wind force (m/s) at a target area spacing of 25 and 50 cm



Band spraying is also no problem for a 25 cm spacing



25 cm nozzle layout: more nozzles, more options, e.g., 3D application



Pneumatic nozzle and section control

AutoSelect

Various combination options with up to 16 storable, different nozzle profiles - to be switched on or off from the cabin. Without interruption, the optimal pressure range that can be configured via the terminal and the corresponding nozzle size are adjusted automatically. Automatic adjustment of the boom height based on the defined nozzle profiles and automatic switching between the nozzle levels. This is based on the nozzle spacings that are stored in the nozzle profiles. Thus, with more nozzles, the farmer has more options.

Fully automatic AutoSelect control system: control of nozzle size or combination while simultaneously adjusting the application rate and the operational speed. High comfort and safety for optimal management of the spacing requirements along waters and terrestrial structures.



AutoSelect menu in the terminal

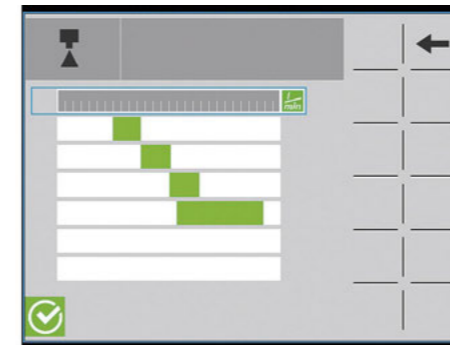

AutoSelect nozzle overlap

- Control of nozzle size and combination while simultaneously adjusting the application rate and the operational speed
- Possibility to adjust not only the pressure range but also the target area spacing to comply with spacing requirements
- Optimal management of spacing requirements along waters and terrestrial structures
- Automatic adjustment of boom height based on the defined nozzle profile
- Can be switched on and off comfortably from the cabin

NightLight

Optimal spraying control at night



Innovative and powerful LED lights ensure an optimum illumination with their heavily focused light which penetrates all spraying cones. Thus, the lighting system guarantees more safety and efficiency while spraying around the clock. A strong LED spotlight is installed per boom side, available with white or blue light, to ensure optimum spraying control at twilight and at night as well as an overview of the nozzle function - also with section control. The automatic light function switches off the headlights on the headlands to avoid blinding, for example, passers-by.

Optionally, NightLight can be combined with an automatic washing system that automatically cleans the lights and prevents dust from settling on the lights. From 30 m boom width or BoomControl Pro Plus, 4 headlights with white or blue light are available for optimal illumination for larger working widths or in challenging terrain at night.

Moreover, LED light strip at the induction centre as well as a LED apron lighting are available.

AutoSelect Pro

AutoSelect Pro takes HORSCH's own nozzle control to the next level. The separate activation of curve compensation allows for combining profiles, thus specifically increasing the application rates on the outer sides of the curves when cornering. At the same time, the application rate is reduced by switching to a smaller nozzle size on the inside of the curve.

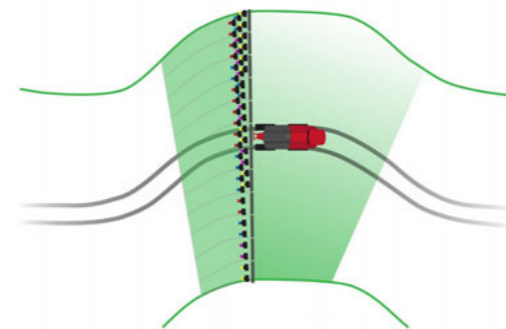

AutoSelect Pro: curve compensation

- All functions of AutoSelect
- Additionally: activation for curve compensation for pneumatic nozzle control
- Adjustment of quantity while cornering by combining profile
- Reduction of over- and underdosage, decrease of resistances

- Innovative LED technology ensures optimum illumination
- Strongly focused light penetrates all spraying cones.
- Optimal spraying control also at dusk and at night
- 100% control of the nozzle function - even with section control
- More safety and efficiency for spraying operations around the clock
- Optional: NightLight with cleaning
- Optional: Choice between white or blue NightLight headlights
- Optional: From 30 m boom width or BoomControl Pro Plus, 4 headlights with white or blue light for optimal illumination for larger working widths or challenging terrain at night
- Optional: light bars at the induction centre and boom apron lighting



NightLight incl. cleaning



NightLight nozzle cone illumination

Steered axle



The kingpin steering on the axle ensures a smooth boom position while at the same time providing high stability. It ensures the most precise following of the sprayer in the tractor tracks and, thus, significantly reduces track damage. Due to the waisted frame design, very large steering angles (up to 28°) are possible despite the soil-protecting tyres with a diameter of 2.05 m, making the sprayer extremely manoeuvrable and track-stable even in uneven terrain. While the steering is automatically blocked in road mode or deactivated at speeds above 16 km/h, it can be overridden manually in the cabin by means of a joystick while manoeuvring or working in the field. When driving straight on, the steering automatically re-centers. The design with a gyroscope on the axle which operates without a sensor – and thus without calibration – is unique and a benchmark among trailed sprayers.

- Kingpin steering for a precise following in the tractor tracks prevents track damage in the crop
- Maximum manoeuvrability and stability on uneven terrain, steering angle up to 28°
- Can be overridden via joystick in the cabin when manoeuvring
- Gyroscope directly on the axle: therefore no calibration required



Steering axle with a steering angle of up to 28° even with large tyres



Maximum crop protection and exact following in the tracks

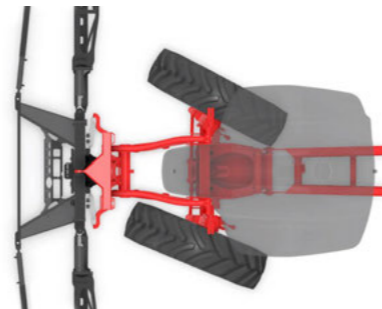

Due to the waisted frame design, a steering angle of up to 28° is possible even with large tyres

Camera steering and preparation

- High-precision control of the crop care sprayer on the row for band application
- Camera steering with a camera for precisely steering the sprayer in row crops
- In challenging conditions, the plant rows can be recorded in 2D or 3D mode.
- Preparation of HORSCH Leeb crop care sprayers ex factory, optionally with CultiCam
- In combination with HORSCH Transformer, to continue using the existing camera
- Including light kit for working at dusk or at night



High-precision steering of the trailed sprayer with CultiCam



Camera steering CultiCam with light kit for working in difficult lighting conditions



Efficient band application of the nozzle directly above the plant row with optional camera steering

Adapted Tire Pressure Control

On-time application in optimal weather conditions sometimes takes place in unfavorable soil conditions. To achieve maximum performance with large tank capacities and working widths while protecting the soil and avoiding compaction, the automatic tyre pressure adjustment Adapted Tyre Pressure Control (ATP) offers a fully ISOBUS software-integrated automatic regulation of the internal tyre pressure. This ensures that, depending on the filling level of the tank, the optimal contact area of the tyre is always achieved during road transport or in field mode so that no compromise between stability and soil protection has to be made. The possibilities of modern tyre technologies are optimally utilised.

- Automatic regulation of tyre inside pressure
- Fully integrated into the ISOBUS software
- No compromises between tank capacity, working width, and soil protection
- Always the optimum tyre contact area in the field and on the road



ATP Control – smooth running with a tyre pressure of 2.3 bar



ATP Control – increased contact area at 1.0 bar tyre pressure

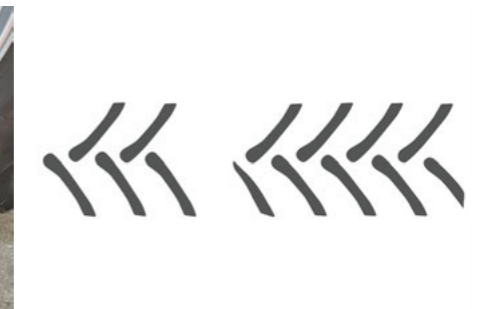

Efficient on the road and gentle in the field with ATP Control

INTELLIGENCE

eosT10 / eosT10 Pro

Due to the high resolution and the well-thought-out user navigation, even complex machine functions can be operated comfortably. The high efficiency and the large (working) memory allow for a smooth handling of large data quantities or application maps. In addition to the traditional import resp. export of data via a USB flash drive, the transfer can also take place easily and conveniently online directly between the PC and the terminal.



By displaying up to 3 widgets in addition to the main working screen, the user can keep track of several applications at the same time

- High-resolution 10" terminal for controlling all ISOBUS devices according to ISO 11783
- Reliable and powerful: high-performance hardware combined with intuitive, user-friendly operation in day or night mode
- Various layout options allow for a simultaneous display of several applications – for an optimum overview
- Straightforward transfer of application maps with the wireless Task Data Exchange
- A real-time transmission of the terminal display via Remote Support facilitates the technical support.



With SpotSpraying, plant protection agents are applied precisely, efficiently, and in an environmentally friendly way.

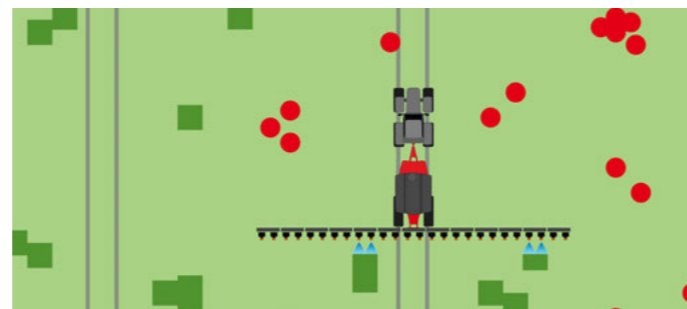

Site-specific application with SpotSpraying or PatchSpraying reduces the use of crop care agents and protects the crops.

HorschConnect

Prepare today for tomorrow. Easily control various machine functions via the HORSCH Control app – your smartphone complements the terminal! Gain comprehensive, transparent insight into work rate and work quality with HorschConnect Telematics.

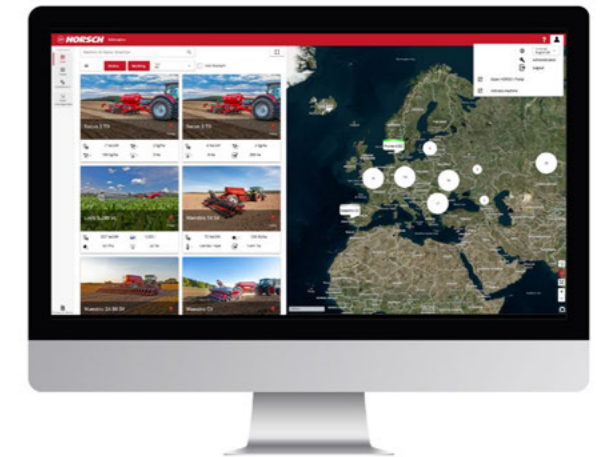

With HorschConnect, telemetry solutions are making their way into the sectors seeding and crop care - exactly where they make sense

- Digital solutions exactly where they make sense
- Straightforward out-of-the-box solution with already integrated SIM card, Wi-Fi modem and other interfaces
- HorschConnect Telematics to document the performance of the machine
- HorschConnect Telematics for complete transparency of the working quality, e.g. the application rate of all components
- Targeted and proactive service by remote access to error messages
- Control of machine functions via the smartphone app HORSCH Control: e.g. carrying out nozzle tests for individual sections

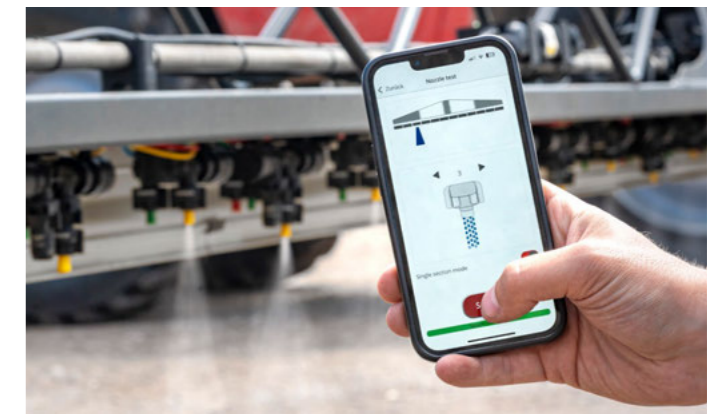

The HORSCH Control app allows for controlling individual machine functions - comfortably with a smartphone



Success factor transparency: position-specific data of all relevant information like error messages, application rate, nozzle status or target area spacing



Digital networking with HorschConnect, GPS, and a weather station for optimal adaptation to current environmental conditions



Comfortably access current and past weather conditions on your PC with the weather station and HorschConnect Telematics

ADDITIONAL EQUIPMENT



52 l stainless steel induction hopper incl. additional shock nozzle



Boom apron lighting



Second pressure filter in the middle frame of the boom



Container deposit



Connect & Fold system – suitable for standard droplegs



Systems for underleaf spraying, e.g. droplegs



MotionControl to smooth the horizontal movements in the boom wings

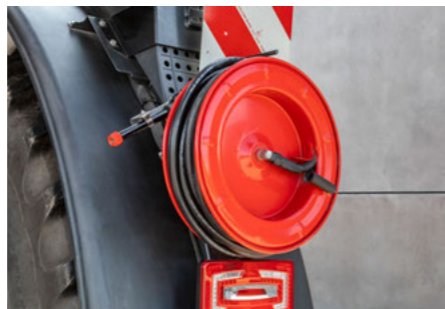

Hose reel for outside cleaning



Hydraulically operated high-pressure cleaner

TECHNICAL DATA

Leeb LT	4 LT	5 LT	6 LT	9 LT
Empty weight (kg)	4250 - 6400	4250 - 6400	4250 - 6400	4950 - 7200
Vertical load empty (kg)	450 - 800	450 - 800	450 - 800	700 - 1200
Max. admissible vertical load (kg)	3000	3000	3000	4000
Axle load empty (kg)	3800 - 5600	3800 - 5600	3800 - 5600	4250 - 6000
Max. admissible axle load (kg)	10000	10000	10000	10000
Total length max. (transport position / m)	7,70	7,70	7,70	8,30
Transport width (transport position / m)	2,55 - 2,55	2,55 - 2,55	2,55 - 2,55	2,55 - 3,00
Transport height (m)	3,40 - 3,60	3,40 - 3,60	3,40 - 3,60	3,40 - 3,60
Track widths (m)	1,80 / 2,00 / 2,10 / 2,25	1,80 / 2,00 / 2,10 / 2,25	2,00 / 2,10 / 2,25	2,00 / 2,10 / 2,25
Clearance (m)	0,85	0,85	0,85	0,85
Mixture tank nominal volume (l)	4000	5000	6000	9000
Mixture tank actual capacity (l)	4400	5300	6400	9500
Fresh water tank (l)	500	500	500	500
Hand wash tank (l)	15	15	15	15
Working widths (m)	18 - 45	18 - 45	18 - 45	18 - 45
Sections (Piece)	6 - 42	6 - 42	6 - 42	6 - 42
Working height (m)	0,3 - 2,5	0,3 - 2,5	0,3 - 2,5	0,3 - 2,5
Pump output CCS and CCS Pro (l/min)	600	600	600	1000
Pump output Basic (l/min)	400	400	400	400
Max. working pressure (Bar)	8	8	8	8
Operational speed (km/h)	4 - 20	4 - 20	4 - 20	4 - 20





Your distributor



HORSCH LEEB
Application Systems SE & Co. KG
Kleegartenstraße 54
94405 Landau an der Isar
Phone: +49 9951 6041-0
Fax: +49 9951 6041-3092
E-Mail: info@horsch.com

horsch.com

Paper: 120 g/qm Maxi Offset. The paper is certified according to the EU Ecolabel. This label is only granted for products and services whose environmental consequences are considerably lower than those of comparable products. For more details see www.eu-ecolabel.de. Printing ink: Printing ink QUICKFAST COFREE. Free from mineral oil and cobalt. Moreover, it is certified and recommended for printing according to the „Cradle-to-Cradle“ principle (quasi “from the origin back to the origin”) – an approach that deals with the spreading of continuous and consequent recycling management. More details at www.c2c-ev.de.

All specifications and diagrams are approximate and not binding. Technical features and design are subject to change.

EN-60208764 (AGRI25)