



Leeb VL

FLEXIBILITY AND EFFICIENCY





Leeb VL

Variable track width and height adjustment

- Highest continuous clearance of up to 2.00 m in field mode even with 8 000 l mixture tank
- Optimum boom position even at high operational speeds due to individual wheel suspension and parallel suspension of the boom
- Practical control terminals and an ergonomic joystick for an intuitive operation, perfectly adapted to the application requirements
- Continuous inside cleaning CCS Pro with electrical valves and external control terminal, spraying and cleaning functions can be controlled in the cabin



With the HORSCH Leeb VL we respond to the requirements for more clearance and flexible track widths. Depending on the crop and season the machine can flexibly adapt to the operational conditions and the challenges to guarantee our customers and their crops utmost efficiency. The Leeb VL has especially been developed for crops that require a very high clearance. Especially in sunflowers and maize the clearance of up to 2.00 m helps to protect the crops and to allow for a on-time plant protection. To be able to react to different row widths, the track can be adjusted continuously from 2.60 m to 3.50 m or from 3.00 m to 4.00 m.

Depending on the conditions of use and the farm structure, the farmer can choose between a 5000 l, 6 000 l or a 8.00 l tank – optionally made of polyethylene or stainless steel. A stainless steel tank is recommended especially when a high quantity of liquid fertiliser or aggressive mixtures are used. The result is an optimum cleaning result in combination with the continuous inside cleaning.

Due to the option to adapt the control terminal in the cabin to the requirements of the operator – depending on the requirement and preferences, easy operation is possible. The joystick, developed especially for a self-propelled crop care sprayer, shows all necessary functions clearly and also allows the driver to freely assign the buttons to be able to adapt the machine even more individually. All these solutions help to provide the driver with a comfortable working environment thus increasing efficiency and performance. The well-known components that make a HORSCH Leeb sprayer unique remain the same. The powerful rotary pump with 1 000 l/min ensures highest suction rates and short filling times. Due to the active BoomControl control system, the liquid is then placed without drift and precisely on the target.



Comfort cabin for optimal working conditions



Highest clearance and a crop-protecting underbody

CONDITIONS OF USE



- Variable clearance: the standard clearance of the Leeb VL amounts to 1.60 m. Due to the hydraulic or mechanical height adjustment, the VL can be adjusted comfortably in the cabin to a clearance of up to 2.00 m.
- Variable track: the track width can also be adjusted comfortably in the cabin between 2.60 m to 3.50 m or from 3.00 m to 4.00 m.
- The pneumatic chassis in combination with the comfortable cabin guarantees a driving experience comparable to a car.

- Efficiency: due to the active boom control system BoomControl, operational speeds of up to 32 km/h can be achieved with a still optimal wetting and drift reduction. In combination with the 25 cm nozzle spacing the result is a powerful self-propelled sprayer.
- Innovations like the pulse width modulation system PrecisionSpray for more possibilities in the plant protection sector.



Theodor Leeb

Highest clearance and flexible track widths, unrivaled with regard to driving comfort and stability – these were the parameters for the development of the Leeb VL. Due to the modular design of the chassis, the farmer can decide which equipments suit his requirements best. The result is a self-propelled sprayer that can be adapted individually to the requirements of the farm.

Basic

Water system Basic

The equipment line Basic the HORSCH Leeb VN and VL are equipped with a 1 000 l/min rotary pump (filling connection 3" through 5-way valve, 2" lines on the suction side). Suction and pressure side are operated via manual multi-way valves. The spraying pressure is monitored with a pressure

- Rotary pump with a capacity of 1 000 l/min
- Filling connection 3" through 5-way valve, 2" lines at the suction side
- Pressure sensor for monitoring the spraying pressure and pressure regulator for adjusting the flow rate
- Suction and pressure side can be operated manually
- Electronic level indicator on the mixture tank



Water system Basic

sensor and a pressure regulator adjusts the flow rate. The tank is equipped with an electronic level indicator. A digital level indicator is available as an option in the terminal.

CCS

ContinuousCleaningSystem

The CCS water system guarantees a continuous inside cleaning of tank, lines and boom. The additional CCS piston diaphragm pump for cleaning pumps clean water into the spray lines, the spraying pump removes the residual mixture from nozzles and the spray lines instead of diluting it. This allows the system to be cleaned quickly, thoroughly and

- Safe and quick cleaning by displacing the mixture from the lines
- Quick cleaning process of the sprayer without having to get off
- Complete control of the cleaning process in the cabin
- Electronic level indicator at the mixture tank with automatic switch-off
- Fast, thorough, and water consumption-optimized cleaning

with an optimised water consumption – without having to get off the machine directly from the cabin – and the sprayer is completely cleaned when leaving the field. To fill the machine, a powerful rotary pump with Load Sensing is used with manual operation for the suction and pressure side.



Water system CCS

CCS Pro

ContinuousCleaningSystem Pro



ContinuousCleaningSystem Pro (CCS Pro)

In addition to the characteristics of the CCS system, for the CCS Pro version several cleaning programs can be started easily and comfortably at the push of a button in the cabin

1. Complete cleaning: rinses injector line – via the filter to the boom – completely with fresh water and then continues with the continuous inside cleaning (CCS) for mixture tank and boom.
2. Dilution: dilute the spraying mixture in the desired ratio with just a few simple steps
3. Intensive washing program: recommended for an extra thorough cleaning, e.g. when changing between crops.
4. Boom cleaning: automatic rinsing of the boom, e.g. if the work is interrupted for several hours
5. Background cleaning: intelligent, continuous inside cleaning that cleans the inside wall of the tank with fresh water while spraying. This prevents deposits on the tank wall.

The pressure control in the system is carried out via the pump speed. The pump only conveys the amount of liquid that is required for spraying plus the defined quantity for the agitator and thus used especially energy-saving. Fresh water as well as mixture tank are equipped with an electric level indicator for automatic washing programs and an automatic switchoff.

- Continuous inside cleaning with several cleaning and rinsing programs, can be operated comfortably in the cabin
- Pressure sensors for pump, agitator, inside cleaning and boom, suction and pressure side electrically controlled
- Operation with a large external terminal with all important induction functions
- Quick cleaning process of the sprayer without having to get off
- Relaxed filling process due to the standard automatic two filling limits
- Automatic filling level dependent agitator performance and switch-off



External control terminal CCS Pro

Water cycle – Basic – Leeb VL

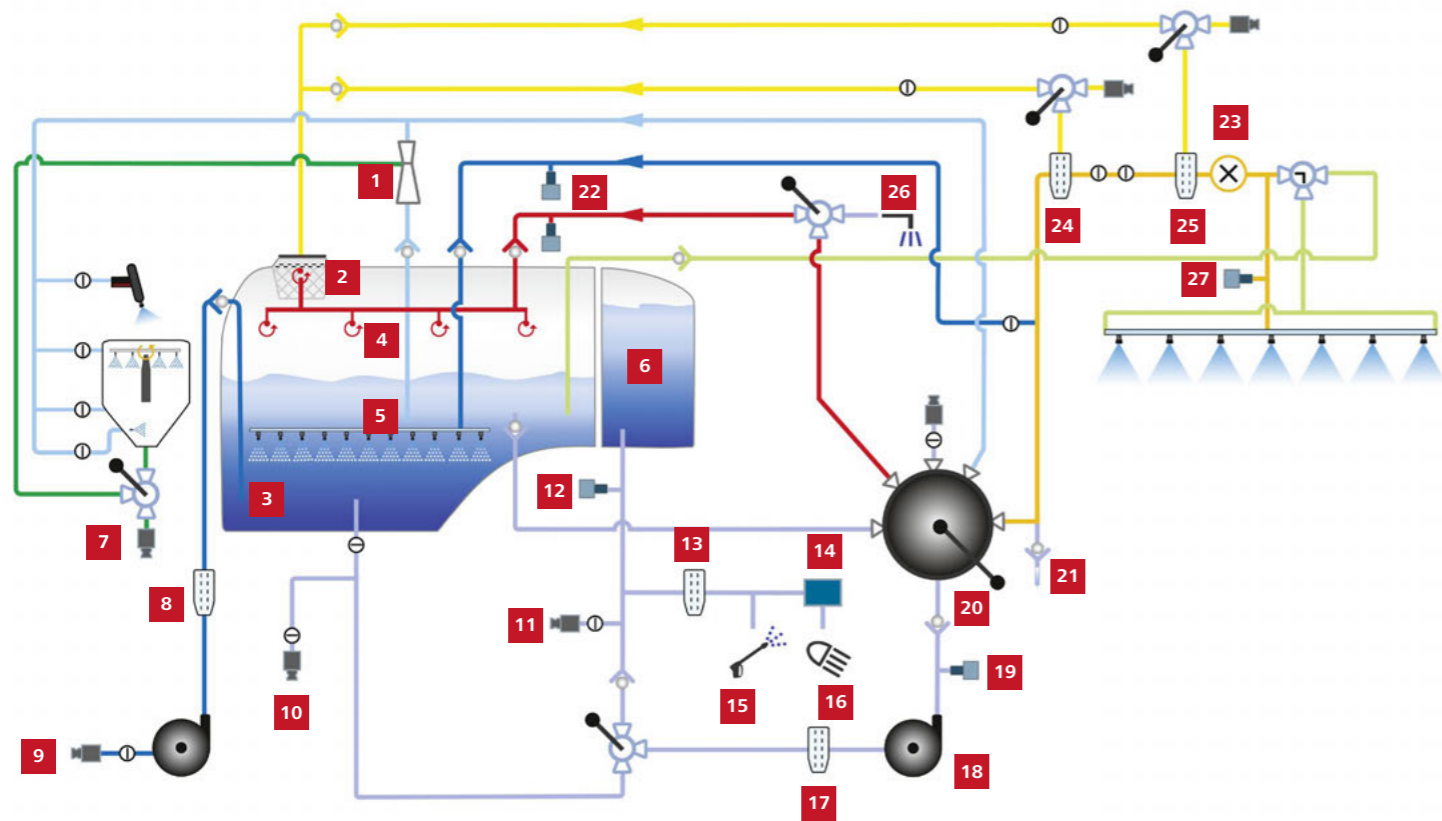

- | | | |
|--------------------------------|---------------------------------|------------------------------|
| 1 Injector | 10 External filling | 19 Pressure sensor |
| 2 Dome sieve | 11 Filling fresh water | 20 Manual 5-way valve |
| 3 Spraying mixture tank | 12 Pressure sensor | 21 Exhaust function |
| 4 Inside cleaning | 13 Fresh water filter | 22 Pressure sensor |
| 5 Agitator | 14 Electric pump | 23 Flow meter |
| 6 Fresh water tank | 15 High-pressure cleaner | 24 1. pressure filter |
| 7 Filling sluice | 16 NightLight cleaning | 25 2. pressure filter |
| 8 Filter | 17 Filter | 26 Outside cleaning |
| 9 Direct filling | 18 Rotary pump | 27 Pressure sensors |

Water cycle – CCS – Leeb VL

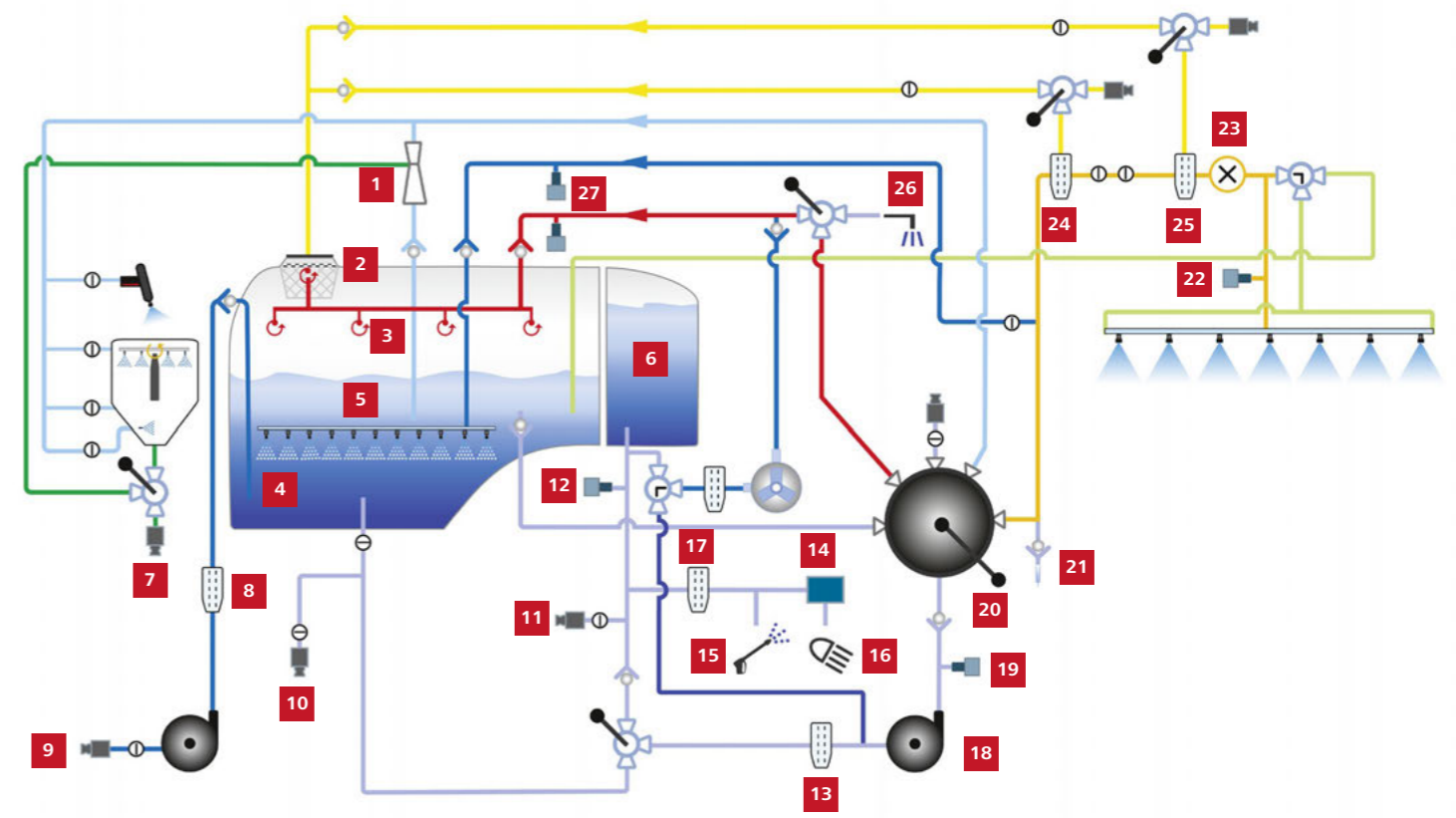

- | | | |
|--------------------------------|---------------------------------|------------------------------|
| 1 Injector | 10 External filling | 19 Pressure sensor |
| 2 Dome sieve | 11 Filling fresh water | 20 Manual 5-way valve |
| 3 Inside cleaning | 12 Pressure sensor | 21 Exhaust function |
| 4 Spraying mixture tank | 13 Filter | 22 Pressure sensor |
| 5 Agitator | 14 Electric pump | 23 Flow meter |
| 6 Fresh water tank | 15 High-pressure cleaner | 24 1. pressure filter |
| 7 Filling sluice | 16 NightLight cleaning | 25 2. pressure filter |
| 8 Filter | 17 Filter | 26 Outside cleaning |
| 9 Direct filling | 18 Rotary pump | 27 Pressure sensors |

Water cycle – CCS Pro – Leeb VL

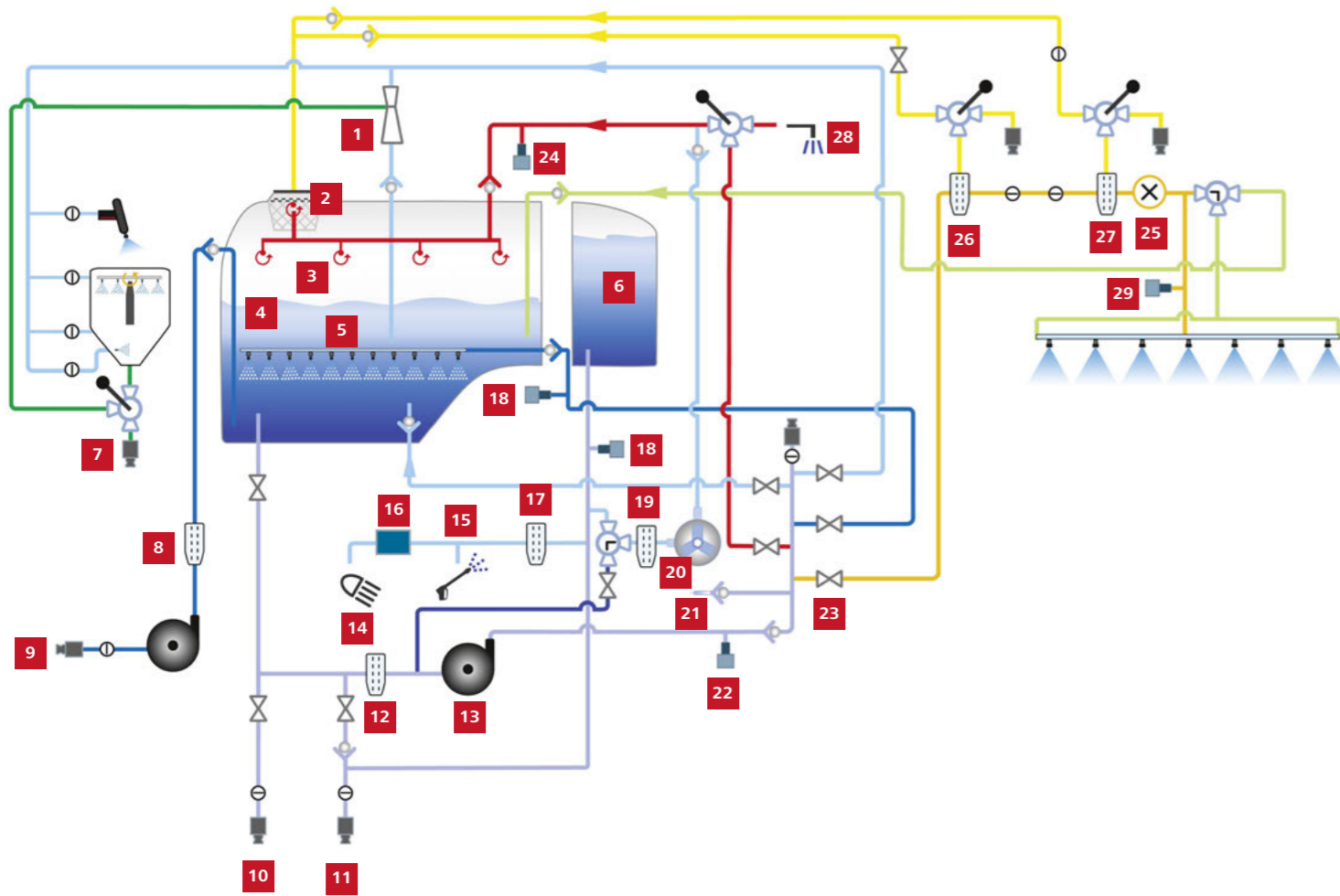

- | | | |
|--------------------------------|---------------------------------|--------------------------------|
| 1 Injector | 11 Filling fresh water | 21 Exhaust function |
| 2 Dome sieve | 12 Suction filter | 22 Pressure sensor |
| 3 Inside cleaning | 13 Rotary pump | 23 Electric switch unit |
| 4 Spraying mixture tank | 14 NightLight cleaning | 24 Pressure sensor |
| 5 Agitator | 15 High-pressure cleaner | 25 Flow meter |
| 6 Fresh water tank | 16 Electric pump | 26 1. pressure filter |
| 7 Filling sluice | 17 Fresh water filter | 27 2. pressure filter |
| 8 Filter | 18 Pressure sensors | 28 Outside cleaning |
| 9 Direct filling | 19 Filter | 29 Pressure sensor |
| 10 Suction filling | 20 Piston diaphragm pump | |

Distribution system and induction hopper

No hose is the best hose

The sophisticated distribution system ensures an optimum supply of boom, intensive agitator, inside tank cleaning and induction hopper. Only one hose and one return flow hose are required for the circulation of the spraying mixture across the entire boom width, thus minimising deposits and facilitating cleaning.

The swivelling induction hopper with a gas pressure absorber and a durable stainless steel labelling is equipped with an efficient injector filling. Upper and lower rinsing nozzles create a whirl-like circulation for quickly flushing-in liquids and are also suitable for granulate. Moreover, the induction hopper is equipped with an additional canister cleaning nozzle as well as a symbol bar with coloured control levers.

As an option, the stainless steel induction hopper pot is available with a capacity of 52 l and the additional shock nozzle.



52 l stainless steel induction hopper incl. additional shock nozzle

- Permanent circulation of the active ingredient solution
- Large tube and line cross sections for optimum circulation, no deposits and blockages
- Permanent spraying fluid at the nozzle, exact switching on and off
- Powerful induction hopper with convincing functions
- Safe cleaning: displacement of the mixture with fresh water

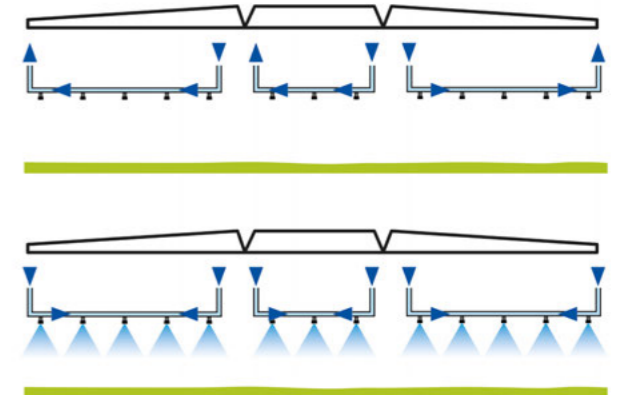

When the pump is running, a mixture circulates continuously in the boom (top) so that it is immediately available at the nozzle when spraying (bottom).

Boom options

Precise technology – sophisticated to the last detail

For the boom, we rely on the well-proven system consisting of a parallelogram suspension and the well-established boom control system BoomControl in working widths from 24 to 48 m which ensures an extremely stable boom position even in very uneven terrain and at high operational speeds. The patented suspension with active, pneumatic control of the middle section avoids boom dipping down

when cornering and on the headlands. The wings of the folding boom are equipped with an overload protection to guarantee safe operation at any time. The weight-optimised design made of durable aluminium profiles protects nozzles, nozzle bodies and spray lines against damage. Different folding options allow for individual solutions for every farm.

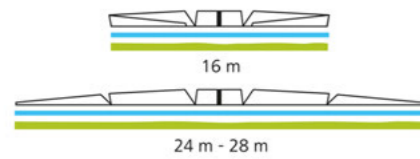

BoomControl - 5-part with reduced working width 16 m

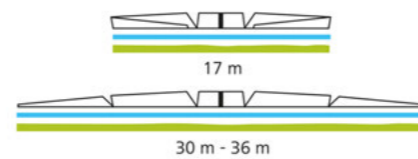

BoomControl – 5-part boom with reduced working width 17 m

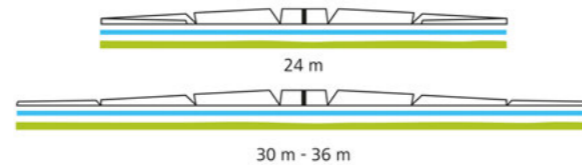

BoomControl - 7-part with reduced working width 24 m

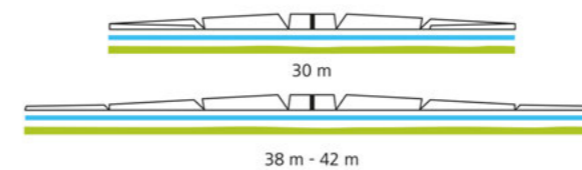

BoomControl - 7-part with reduced working width 30 m

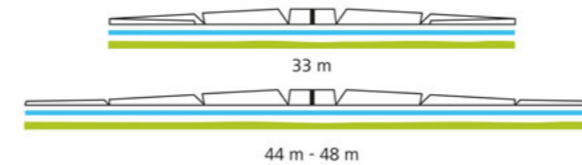

BoomControl – 7-part boom with reduced working width 33 m

- Parallelogram suspension with BoomControl for stable boom position in all conditions
- Patented suspension with active, pneumatic control of the middle section
- 25 boom versions in working widths from 24 to 48 m
- Stable aluminium profile for safe protection of the nozzles, nozzle bodies and spray lines against damage
- Collision protection due to overload protection and damping of the wings
- Overload protection of the outside wings towards the rear, damping of the inside wings towards the front and rear

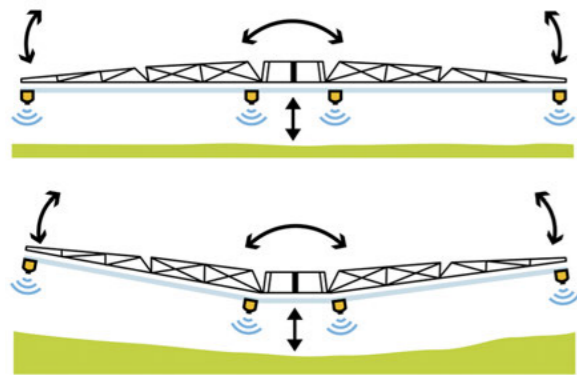

BoomControl Pro – active adaption of the boom to the terrain by means of four sensors

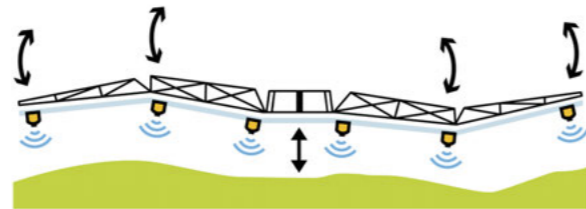

BoomControl Pro Plus

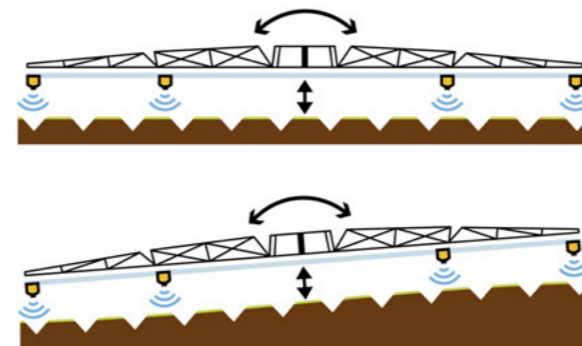

BoomControl/BoomControl Pro extension – extension of the field of vision is ideal for ridge and row crops

BoomControl Pro

Active boom control system
BoomControl Pro

- Independent angling of the boom arms and rotation of the middle section to adapt to the terrain
- Active adjustment of the boom to the terrain with 4 sensors
- Maintenance of the exact, lowest possible working height due to automatic boom control system
- Boom control system with a target area spacing of less than 40 cm ensures minimal drift
- Boom is completely decoupled from the vehicle

BoomControl Pro Plus

Active boom control system
BoomControl Pro Plus

- Independent angling of the boom arms and rotation of the middle section to adapt to the terrain
- Angling (lifting and lowering) of the two outside wings
- Active adjustment of the boom to the terrain by via sensors
- Maintenance of the exact, lowest possible working height due to automatic boom control system
- Boom control system with a target area spacing of less than 40 cm ensures minimal drift

Extension

BoomControl/BoomControl Pro

- Active adaption of the boom to the terrain by means of two additional sensors
- To extend the field of vision
- Ideal for ridge and row crops or for reduced working widths

PrecisionSpray

Pulse width modulation – state-of-the-art application technology



PrecisionSpray is a pulse nozzle system that triggers the nozzles in a pulsating way at a frequency of 20 Hertz. This allows for adjusting the application steplessly via the Duty Cycle – with constant pressure and drop size at variable speed and while maintaining the spraying characteristics. This allows for using larger nozzles which are less susceptible to clogging, and the number of necessary nozzle sizes are minimised. For optimal longitudinal and transverse distribution, the nozzles are switched alternately. The system

is fully integrated into ISOBUS and the HORSCH sprayer software: with curve compensation and the use of application maps, over- and underdosage can be avoided actively. Active resistance management and even populations with minimal mixture consumption make the nozzle a tool for Precision Farming.

- Infinitely variable adjustment of the flow rate at constant pressure and droplet size
- Constant drop spectrum when using a nozzle
- Fewer different nozzle sizes required
- Adjustment of the application rate without altering spraying characteristics
- Curve compensation and VariableRate per section
- Generally larger nozzle bodies that are less prone to clogging

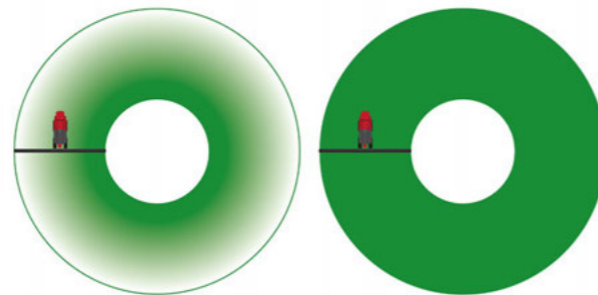

Avoid over and under applying due to curve compensation

Pneumatic nozzle and section control

Performance due to diversity

Due to the pneumatic nozzle control and the pneumatic section control, it is possible to precisely switch off nozzles and sections with compressed air. Nozzle spacings of 25 cm and 50 cm are available.

This allows for individual and intelligent application technologies to achieve optimal penetration and wetting of the crop. Variable nozzle body combinations (pneumatically switchable) can also be used. All nozzles are controlled

individually and are pneumatically combined in sections. This also facilitates maintenance and the easy detection and repair of errors and blockings at the nozzles. As standard, all nozzle body configurations are equipped with nozzle holders for edge nozzles. Comprehensive tests in our wind tunnel show considerable advantages with regard to the drift behaviour depending on the target height.

- Individually controlled nozzles, combined pneumatically in sections
- 6 to 42 possible sections (standard sections or individual configuration options)
- Excellent penetration and wetting of the population
- Optimum target area spacing with a nozzle spacing of 25 cm
- Allows for individual and intelligent application technologies

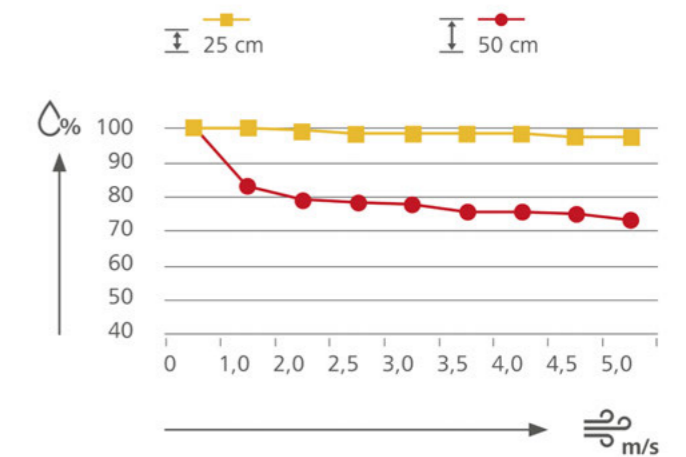

Drift comparison: wetting (in %) depending on the wind force (m/s) at a target area spacing of 25 and 50 cm



Band spraying is also no problem for a 25 cm spacing



25 cm nozzle layout: more nozzles, more options, e.g., 3D application



Pneumatic nozzle control 2-2 with 3D application

AutoSelect

Various combination options with up to 16 storable, different nozzle profiles – to be switched on or off from the cabin. Without interruption, the optimal pressure range that can be configured via the terminal and the corresponding nozzle size are adjusted automatically. Automatic adjustment of the boom height based on the defined nozzle profiles and automatic switching between the nozzle levels. This is based on the nozzle spacings that are stored in the nozzle profiles. Thus, with more nozzles, the farmer has more options.

Fully automatic AutoSelect control system: control of nozzle size or combination while simultaneously adjusting the application rate and the operational speed. High comfort and safety for optimal management of the spacing requirements along waters and terrestrial structures.



AutoSelect menu in the terminal

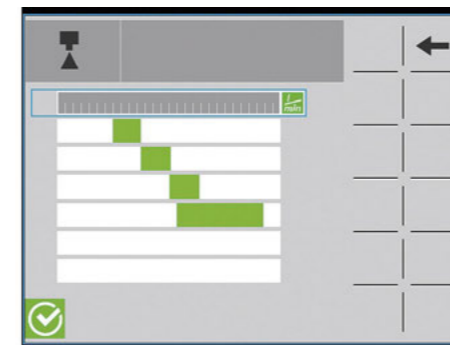

AutoSelect nozzle overlap

- Control of nozzle size and combination while simultaneously adjusting the application rate and the operational speed
- Possibility to adjust not only the pressure range but also the target area spacing to comply with spacing requirements
- Optimal management of spacing requirements along waters and terrestrial structures
- Automatic adjustment of boom height based on the defined nozzle profiles
- Can be switched on and off comfortably from the cabin

AutoSelect Pro

AutoSelect Pro takes HORSCH's own nozzle control to the next level. The separate activation of curve compensation allows for combining profiles, thus specifically increasing the application rates on the outer sides of the curves when cornering. At the same time, the application rate is reduced by switching to a smaller nozzle size on the inside of the curve.

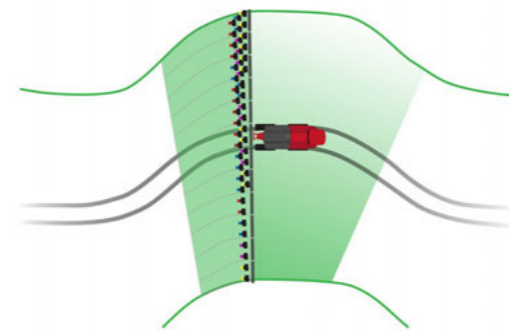

AutoSelect Pro: curve compensation

- All functions of AutoSelect
- Additionally: activation for curve compensation for pneumatic nozzle control
- Adjustment of quantity while cornering by combining profiles
- Reduction of over- and underdosage, decrease of resistances

NightLight

Optimal spraying control at night



Innovative and powerful LED lights ensure an optimum illumination with their heavily focused light which penetrates all spraying cones. Thus, the lighting system guarantees more safety and efficiency while spraying around the clock. A strong LED spotlight is installed per boom side, available with white or blue light, to ensure optimum spraying control at twilight and at night as well as an overview of the nozzle function – also with section control. The automatic light function switches off the headlights on the headlands to avoid blinding, for example, passers-by.

Optionally, NightLight can be combined with an automatic washing system that automatically cleans the lights and prevents dust from settling on the lights. From 30 m boom width or BoomControl Pro Plus, 4 headlights with white or blue light are available for optimal illumination for larger working widths or in challenging terrain at night.

Moreover, LED light strip at the induction centre as well as a LED apron lighting are available.

- Innovative LED technology ensures optimum illumination
- Strongly focused light penetrates all spraying cones.
- Optimal spraying control also at dusk and at night
- 100% control of the nozzle function – even with section control
- More safety and efficiency for spraying operations around the clock
- Optional: NightLight with cleaning
- Optional: Choice between white or blue NightLight headlights
- Optional: From 30 m boom width or BoomControl Pro Plus, 4 headlights with white or blue light for optimal illumination for larger working widths or challenging terrain at night
- Optional: light bars at the induction centre and boom apron lighting



NightLight incl. cleaning



NightLight nozzle cone illumination

Ergonomic operating concept

Innovative operation with the highest requirements on the workplace

The cab of the HORSCH self-propelled sprayer offers numerous comfort features as well as an innovative and well-thought-out operating concept.

Machine, driving, and spraying data can be displayed and individually configured via the bright and high-resolution 12" A-column display. The camera views and the programming of the joystick are also displayed. The display is operated via buttons in the armrest in a comfortable seating position. The in-house developed control lever offers 30 freely assignable buttons on different levels and an ergonomic cork grip shell. With the new softkey „Sprayer Ready," circulation, agitator, all-wheel steering, and BoomControl are activated at the push of only one button.

The ergonomic steps fold in fully automatically as soon as the vehicle moves, and quickly fold out again if the operator stops the vehicle. This ensures that the ladder is always raised while spraying and crop damage is prevented.

The glazed cabin offers an excellent circumferential visibility and a lot of free moving space for long working days. A comfortable footrest helps to find a relaxed position behind the wheel at any time. The integrated DAB radio with Bluetooth function and hands-free system is conveniently operated via the armrest. An integrated mobile phone holder with inductive charging function is included. Numerous storage compartments, the actively cooled 30 l cool box, and the automatic climate control ensure comfort during long working days. For user protection, a Cat. IV cabin filtering is already prepared and fully integrated into the cabin. The operation of the air conditioning system and the control of the up to 18 LED working lights to monitor the work quality are integrated into the roof rail.

A pneumatic 4-point cabin suspension and a safety bar for the bumper are available as an option.

- Automatic air-conditioning/heating, operation of the air-conditioning function and lighting integrated in the roof strip
- Control lever with multi-configurable keys integrated in an ergonomic control armrest
- 12" display in the A-column with customisable main page, machine, driving, and spraying data

- Armrest with new machine functions, e.g. „Sprayer Ready" - pump start + BoomControl
- Preparation for automatic Cat. IV cabin filtering (automatic control, fully integrated into cabin roof and roof ledge)



Comfortable and spacious cabin with joystick, mobile phone holder, and cup holder

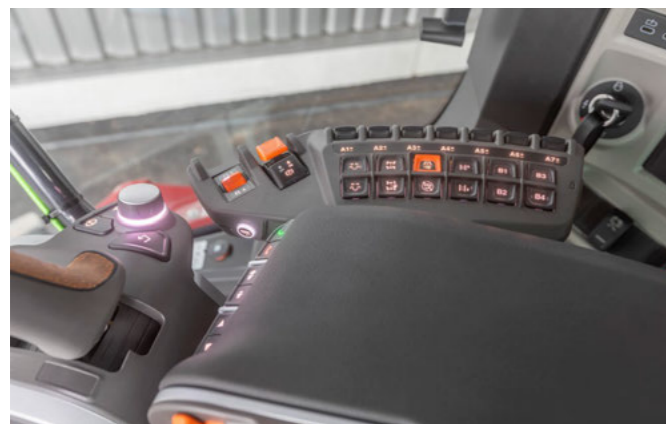

Comfortable operation of the functions compactly integrated into the armrest



Ergonomic control lever with multiply assignable buttons



Safe operation of the A-column display: rotary/push functions



Standard 12" A-column display with customisable display options



Cabin with large glass surfaces for optimum circumferential visibility

Cabin Pro

Optimal circumferential visibility and utmost comfort

In addition to the standard equipment, the Pro line offers a swivelling and air-suspended comfort leather seat with heating and ventilation as well as a passenger seat with leather padding. A lumbar support to relieve the spine and a headrest are integrated into the high backrest of the driver's seat, there is a foldable armrest on the left side. The damping and the longitudinal suspension of the premium seat can be adjusted in many ways. A triple cup holder is mounted for long workdays. With the integrated sun protection blinds at the front, rear and side windows, the light incidence and thus the heat development in the cabin can be regulated on sunny and hot days. In addition, there is a floor mat made of velour and a terminal mounting rail.



Comfort leather seat for fatigue-free working

Cabin Basic

Front cabin with optimum visibility and circumferential view

The Basic equipment options offers the driver a length- and height-adjustable driver's seat covered with durable fabric and a passenger seat also covered with fabric. The spring-loaded and comfortably cushioned driver's seat has a backrest with an integrated lumbar support to relieve the spine and is equipped with an armrest on the left side. A double cup holder is integrated for long workdays. Sun protection blinds are mounted on the front and rear windows.

- Fabric seat with various adjustment options
- Double cup holder made of plastic for long workdays
- Sun protection blinds on front and rear windows

- Swivelling comfort seat with premium leather cover
- Seat heating and ventilation
- Triple cup holder for long workdays
- Sun protection blinds on front, rear and side window
- Additionally, there is a foot mat and a terminal mounting rail.



Cab Pro with comfort leather seat and leather passenger seat



Velours floor mat



Large cup holder



Cabin Basic with comfortable entry



Practical cup holder

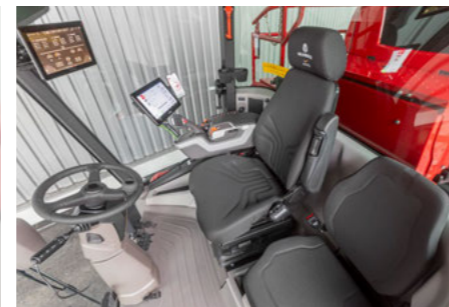

Comfortable passenger seat with fabric cover



Standard footrest



Storage facility under the driver seat with optional safety package



Spacious cooling compartment as standard

Wheel drive PowerGear

Powerful all-wheel drive for optimal performance

The drive PowerGear allows for optimum performance in the field and also on the road. Equipped with a standard anti-slip control and all-wheel drive, the vehicle operates effortlessly in any terrain. The efficiency factor that has specifically been optimised for the use in the crop care sector with larger wheel motors on the rear axle and the associated higher drive power distribute drive torques powerfully and efficiently in the speed range of 0 – 50 km/h with tyre options up to Ø 2.19 m. This drive is ideal in combination with the more powerful engines for machines with larger mixture tanks and large booms.

- Powerful all-wheel drive even in steep terrain and on slopes
- Degree of efficiency in the main working range has been specially optimised for the use in the crop care sector
- Selective traction control for every wheel
- Infinitely variable drive from 0 – 50 km/h
- With tyres up to Ø 2.19 m
- Up to 230 ccm displacement of the wheel motors

Wheel drive HighPowerGear

Intelligent all-wheel drive for highest requirements

For farmers who want or have to push the limits, there is HighPowerGear: more driving power when starting, more reserves in wet conditions and more torque in the low-speed range for the highest requirements in the field. HighPowerGear shows its strength especially with low operational speed and extreme slopes of up to 50 %. When driving slowly below 8 km/h or if the machine is on the verge of getting stuck, HighPowerGear provides the required power reserves to manage the most difficult situations.

- Maximum torque at the wheel for highest requirements in the field
- Can cope with slopes up to 50 %
- Selective traction control for every wheel
- Infinitely variable drive from 0 – 50 km/h
- Degree of efficiency in the main working range has been specially optimised for the use in the crop care sector
- Up to 340 ccm displacement of the wheel motors



The HighPowerGear wheel drive provides the required power reserves to manage the most difficult situations

TrackControl

Adapting the track width in the cabin



Flexibility and efficiency

The hydraulic flange adjustment TrackControl allows for a reliable and comfortable adjustment of the track width of the self-propelled sprayer HORSCH Leeb VL.

The track width can be adjusted infinitely between 2.60 and 3.50 m resp. between 3.00 and 4.00 m to react to any crop and row width. Tramlines can be avoided and stability and driving characteristics improve while spraying.

- Hydraulic adjustment of the track width in the cabin
- Adaption to different crops and row widths
- Track width 2.60 to 3.50 m resp. 3.00 to 4.00 m

ClearanceControl

Hydraulic height adjustment ClearanceControl

With ClearanceControl, the clearance can be adjusted hydraulically and steplessly to maintain the optimal spraying distance at all times and to protect the crops when passing. The clearance height can be comfortably adjusted directly in the cabin within the range of 1.60 m to 2.00 m. Thus, the sprayer can be quickly and effectively adjusted to changing crops and growth heights or optimally set for road transport.

- Stepless adjustment of the clearance
- Can be operated comfortably, fast and effectively in the cabin
- Clearance height adjustable from 1.60 to 2.00 m
- Highest clearance in the market



Hydraulic height adjustment ClearanceControl

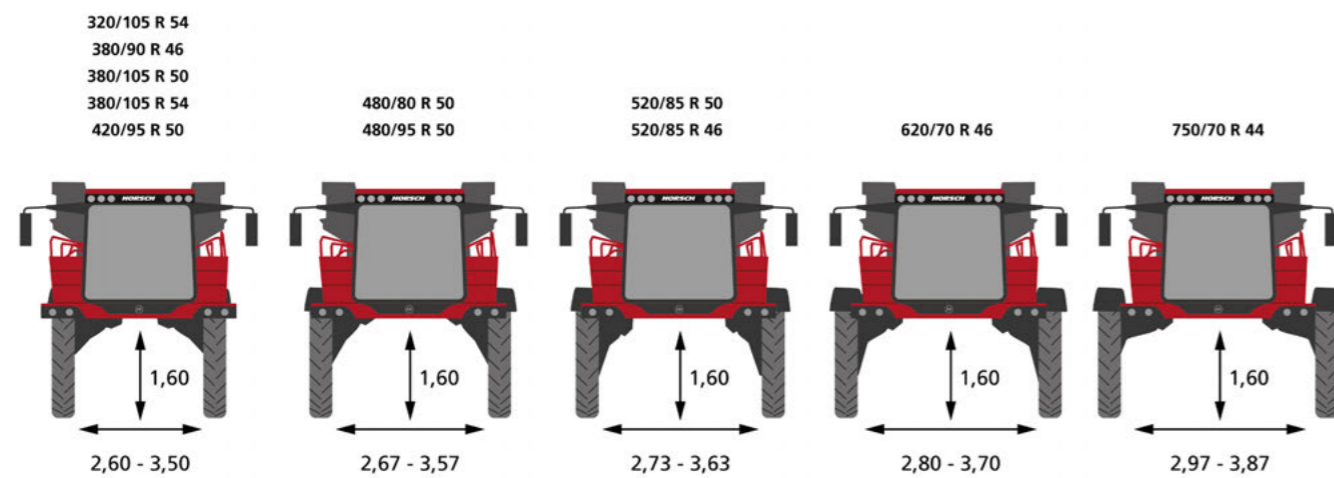

Track widths from 2.60 to 3.87 m in the bottom position

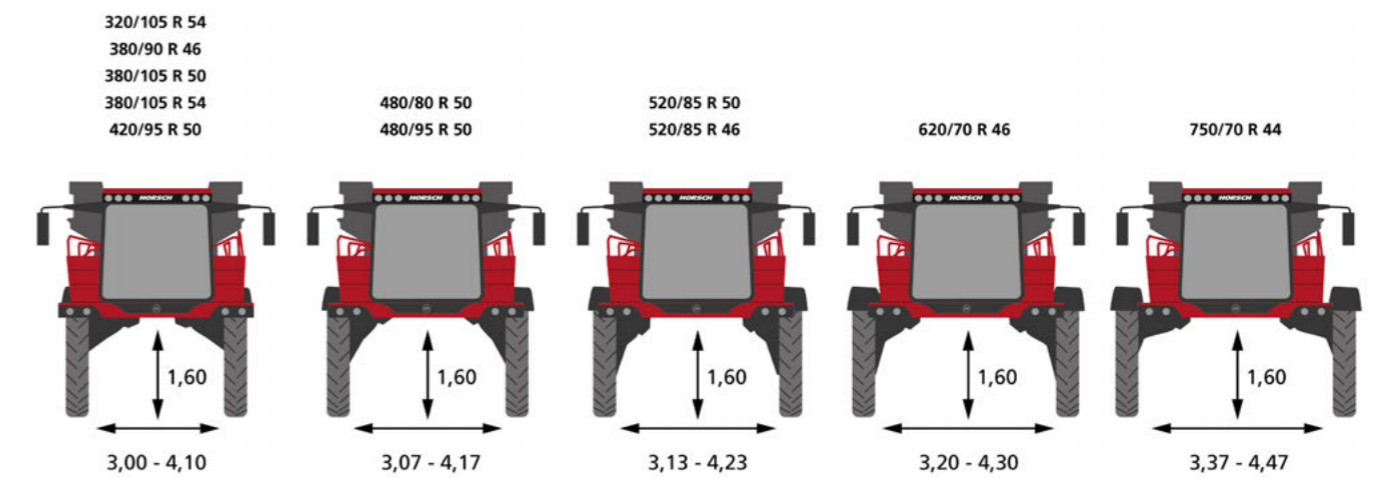

Track widths from 3.00 to 4.47 m in the bottom position

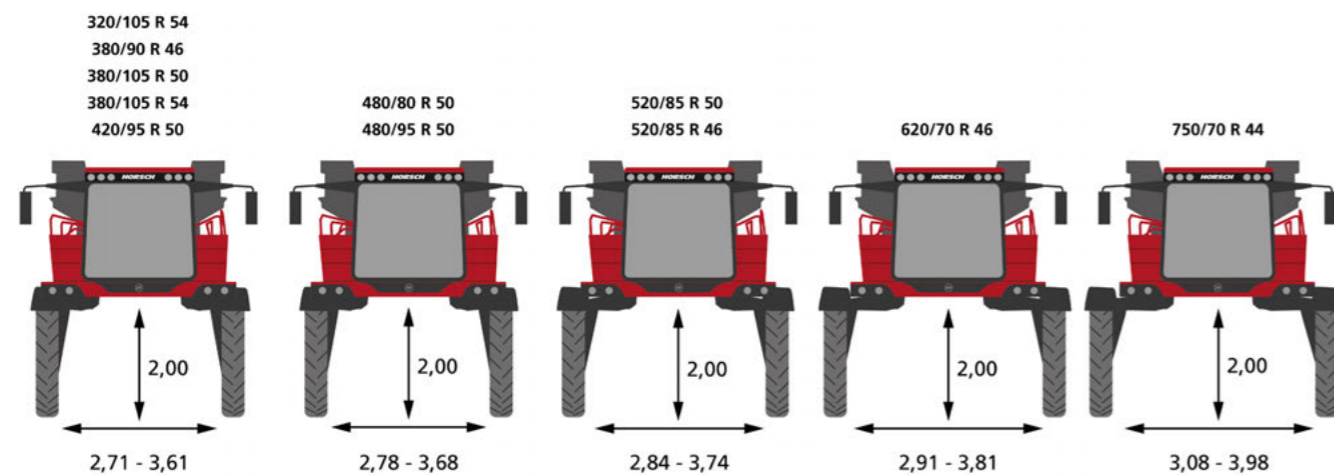

Track widths from 2.71 to 3.98 m in the top position

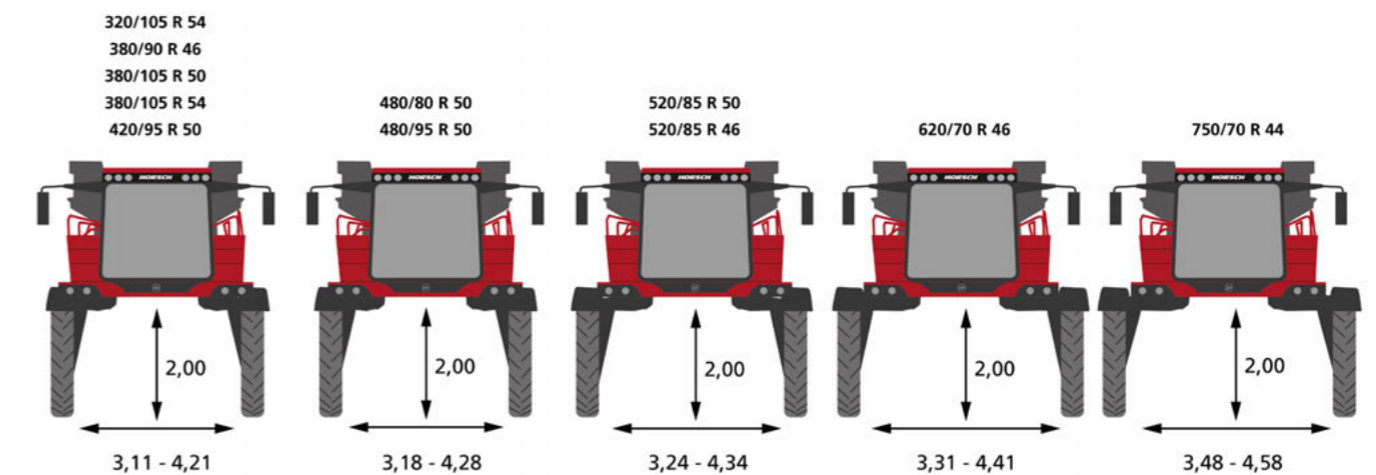

Track widths from 3.11 to 4.58 m in the top position

HillControl

With the equipment HillControl, the rear axle of the self-propelled HORSCH Leeb crop care sprayer is controlled separately. This ensures safe trafficability on side slopes even in difficult conditions. The slipping of the machine is actively overridden, and the aggressiveness of the steering is adjusted infinitely.

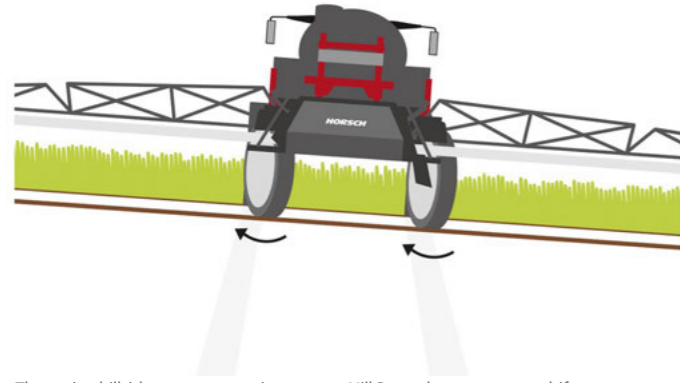

The active hillside counter-steering system HillControl compensates drift on side slopes and ensures a directionally stable following of the rear axle.

Operation is extremely easy: activate HillControl and slightly adjust the steering to the conditions if necessary. The system stores the values until the next folding of the boom – in every driving direction across the entire field.

- Exact following in the tracks of the rear axle on side slopes
- Active hillside counter-steering, aggressiveness infinitely adjustable
- Easy operation, stored values are retrieved in each driving direction
- Safer trafficability on side slopes in demanding conditions

HillControl Pro

Active compensation of the vehicle chassis on side slopes

HillControl Pro takes the automatic side slope compensation to the next level.

The separate activation of HillControl Pro allows for using the 400 mm adjustment range of the hydraulic height adjustment ClearanceControl to independently lift or lower each side of the vehicle. The combination of HillControl Pro and ClearanceControl effectively stabilizes the vehicle chassis on side slopes and keeps it in a horizontal position. At the same time, the active control of the rear axle HillControl ensures that the vehicle maintains a stable track

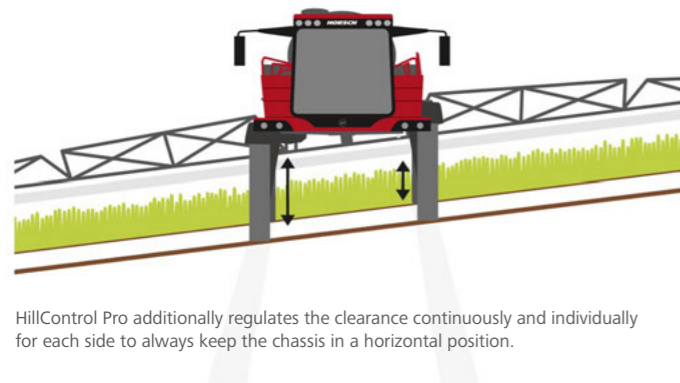

HillControl Pro additionally regulates the clearance continuously and individually for each side to always keep the chassis in a horizontal position.

on side slopes. Depending on the model variant, track width, and cylinder travel, the chassis can compensate for lateral inclinations of approx. 4% to 18%. In this context, the maximum possible clearance on the uphill side is limited due to the slope compensation.

This does not only ensure comfort in the cabin and for the workplace but also stability on side slopes. The additional function runs in the background - completely automatic, responsive and active.

- Active compensation of the vehicle chassis on side slopes
- In combination with ClearanceControl, the vehicle chassis is permanently adapted to the side slope.
- Comfortable workplace in the cabin and optimum center of gravity of the machine in relation to the slope
- Only in combination with HillControl: rear axle precisely follows the tracks on side slopes

Central lubrication unit

With the PowerFill filling pump, the sprayer can be filled directly in the field with unfolded boom within a very short time. The pre-mixed mixture is pumped directly from a carrier vehicle into the tank with a pump capacity of up to 1 000 l/min, minimizing filling times.

- Reduces maintenance effort and maximizes operating comfort
- Shorter idle times
- Optimal lubrication

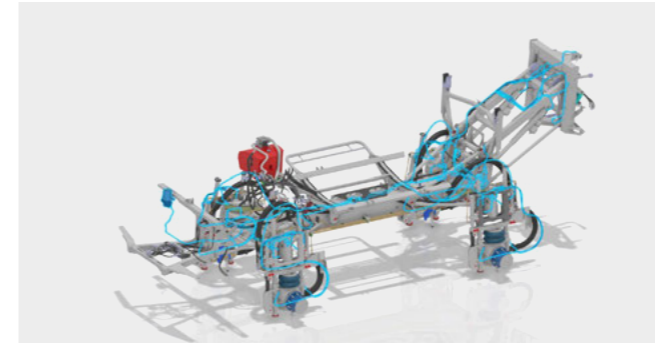

Central lubrication unit for the axles and the parallelogram



Tank of the central lubrication unit

PowerFill filling pump

Filling connection 3" with PowerFill filling pump

The central lubrication units facilitates and automates the maintenance and care of the chassis, telescopic axles and the parallelogram. This reduces the maintenance effort and shortens idle time.

- Reduces travel, idle and filling times
- Powerful pump with filling capacity of up to 1 000 l/min
- Filling in the field with unfolded boom possible
- 3" filling connection for pre-mixed mixture



Filling in the field with unfolded boom

INTELLIGENCE

Terminal technology & steering system

Tractor terminal 1060 or 1260 with steering system

The new terminal generation Trimble 1060 or 1260 allows for controlling the machine at top level. Due to the high resolution and the sophisticated user navigation, complex machine functions can be operated comfortably. The high efficiency and the large (working) memory allow for a smooth handling of large data quantities or application maps. Thus, it becomes the perfect all-rounder for machine operation.

Combined with a completely integrated steering system with receiver, the application of your self-propelled crop care sprayer becomes even more precise and the driving comfort is maintained even on long working days. The activation VariableRate completes the precision solutions when working with application maps.

- Intuitive machine operation via the high-resolution Trimble Terminal 1060 or 1260
- Optional extension by a second terminal or optional control via different approved external terminals
- Fully integrated steering system with receiver Trimble Nav 900
- Additional activation of VariableRate for site-specific variable application by means of application maps



High-resolution Trimble terminal with large screen



High-resolution Trimble terminal with large screen



Receiver Trimble Nav 900

HorschConnect

Prepare today for tomorrow. Easily control various machine functions via the HORSCH Control app – your smartphone complements the terminal! Gain comprehensive, transparent insight into work rate and work quality with HorschConnect Telematics.

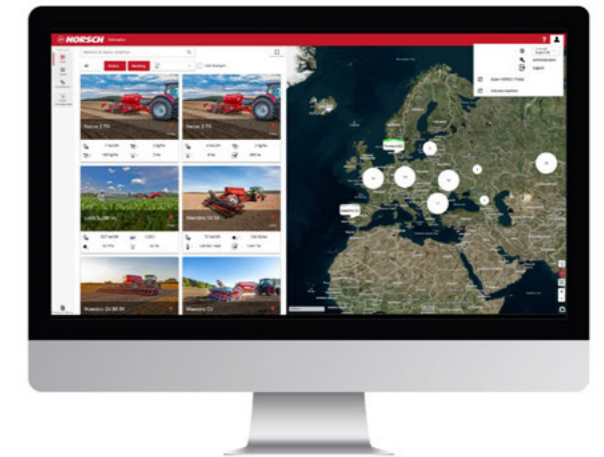

With HorschConnect, telemetry solutions are making their way into the sectors seeding and crop care - exactly where they make sense

- Digital solutions exactly where they make sense
- Straightforward out-of-the-box solution with already integrated SIM card, Wi-Fi modem and other interfaces
- HorschConnect Telematics to document the performance of the machine
- HorschConnect Telematics for complete transparency of the working quality, e.g. the application rate of all components
- Targeted and proactive service by remote access to error messages
- Control of machine functions via the smartphone app HORSCH Control: e.g. carrying out nozzle tests for individual sections

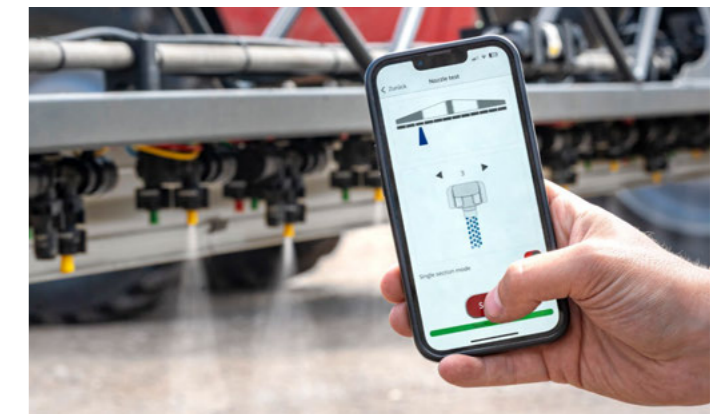

The HORSCH Control app allows for controlling individual machine functions - comfortably with a smartphone



Success factor transparency: position-specific data of all relevant information like error messages, application rate, nozzle status or target area spacing



Digital networking with HorschConnect, GPS, and a weather station for optimal adaptation to current environmental conditions



Comfortably access current and past weather conditions on your PC with the weather station and HorschConnect Telematics

Camera system

Up to three high-resolution cameras can be mounted ex factory and transmit their footage to the 12" A-column display in the cabin. The display of the camera images can be adjusted at any time and adapted to the current requirements. The rear view camera is mounted on the middle section of the boom. The image is automatically zoomed to full screen size when going into reverse, showing the area behind the vehicle to facilitate manoeuvring. The lens with a view of the right front wheel helps the driver to keep the track precisely and to avoid damage to the population. The camera on the NightLight holder focuses on the nozzles behind the vehicle when the boom is folded out, allowing for keeping an eye on the function of the nozzles hidden behind the tank at all times.



High-resolution, automatic display of the rearview camera in the A-column display



Rear view camera for monitoring the area behind the vehicle



High-resolution, individual display of the track camera in the A-column display



Camera for nozzle monitoring on the NightLight holder

Multimedia system

Clear sound, clear information – sure thing.

The multimedia system offers maximum comfort due to a user-friendly interface and intuitive operation. The DAB+ radio allows for interference-free reception. The simple connection of the smartphone allows for accessing all Apple CarPlay or Android Auto functions. The installation of improved microphones and a separate subwoofer allow for crystal-clear conversations and a rich music experience.

- Maximum comfort and optimised acoustics
- Always informed due to DAB+ digital radio reception
- Smartphone integration with Apple CarPlay and Android Auto
- Clear communication due to improved hands-free equipment
- Subwoofer for rich sound

ADDITIONAL EQUIPMENT



52 l stainless steel induction hopper incl. additional shock nozzle

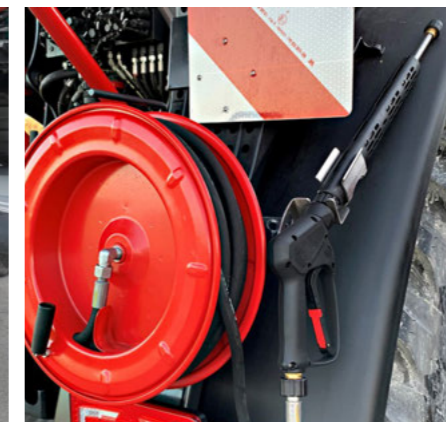

Hydraulically operated high-pressure cleaner

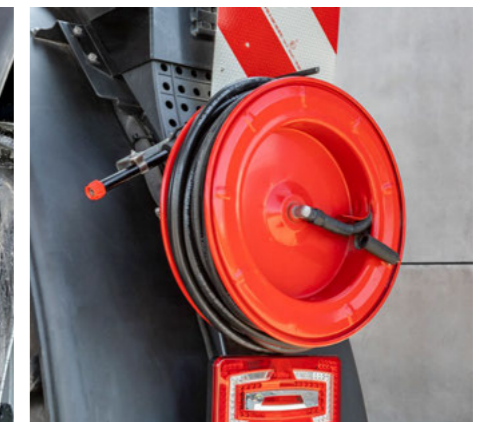

Hose reel for outside cleaning



Wheel housing for sensitive crops



Pneumatic 4-point cabin suspension

TECHNICAL DATA

Leeb VL	5.300 VL	6.300 VL	8.300 VL	6.460 VL	8.460 VL
Mixture tank nominal volume (l)	5000	6000	8000	6000	8000
Water-cooled engine	FPT (Fiat Powertrain Technologies) N67	FPT (Fiat Powertrain Technologies) N67	FPT (Fiat Powertrain Technologies) N67	FPT (Fiat Powertrain Technologies) Cursor 9	FPT (Fiat Powertrain Technologies) Cursor 9
Nominal power (for rpm) (kW/hp)	212 / 288 (2200)	212 / 288 (2200)	212 / 288 (2200)	308 / 419 (2100)	308 / 419 (2100)
Maximum power (for rpm) (kW/hp)	230 / 313 (2000)	230 / 313 (2000)	230 / 313 (2000)	338 / 460 (2000)	338 / 460 (2000)
Cylinder number/cooling	6 / water / turbo with charge air cooling	6 / water / turbo with charge air cooling	6 / water / turbo with charge air cooling	6 / water / turbo with charge air cooling	6 / water / turbo with charge air cooling
Cylinder capacity (cm ³)	6700	6700	6700	8700	8700
Max. torque (Nm/Speed)	1160 / 1500	1160 / 1500	1160 / 1500	1800 / 1500	1800 / 1500
Control	Electronic EMR	Electronic EMR	Electronic EMR	Electronic EMR	Electronic EMR
Tank capacity diesel/AdBlue (l)	Approx. 450/45	Approx. 450/45	Approx. 450/45	Approx. 720/72	Approx. 720/72
Emission standard	Stage V	Stage V	Stage V	Stage V	Stage V
Working widths (m)	24 - 48	24 - 48	24 - 48	24 - 48	24 - 48



Your distributor



HORSCH LEEB Application Systems GmbH
 Kleegartenstraße 54
 94405 Landau an der Isar
 Phone: +49 9951 6041-0
 Fax: +49 9951 6041-3092
 E-Mail: info@horsch.com

horsch.com

<p>Paper: 120 g/qm Maxi Offset. The paper is certified according to the EU Ecolabel. This label is only granted for products and services whose environmental consequences are considerably lower than those of comparable products.</p>

<p>For more details see www.eu-ecolabel.de. Printing ink: Printing ink QUICKFAST COFREE. Free from mineral oil and cobalt. Moreover, it is certified and recommended for printing according to the „Cradle-to-Cradle“ principle (quasi “from the origin back to the origin”) – an approach that deals with the spreading of continuous and consequent recycling management. More details at www.c2c-ev.de.</p>

EN-60208780 (AGRI25)